

**INSTALLATION
OPERATION
& MAINTENANCE**

**Packaged Terminal Air Conditioners
DM Series**

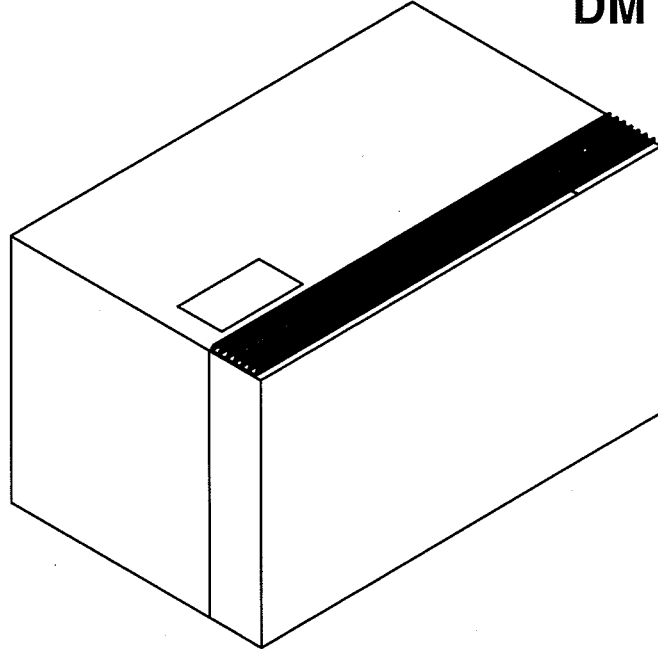

**Dual Motor Cooling with
Electric Heat**

TABLE OF CONTENTS

Chapter	Page Number
1 Installation Checklist	1
2 Electrical Requirements	3
3 Chassis Installation	6
4 Unit Operation	7
5 Startup Checklist	10
6 Routine Maintenance	11
7 Operational Practices	13

1

Installation Checklist



WARNING

Electric shock hazard.

Turn off electric power before service or installation.

Read these instructions carefully and completely before attempting installation. Unit should be installed by qualified service personnel **ONLY**.

Failure to do so can result in property damage, personal injury and/or death.

The installation and operation may vary from the instructions in this manual depending on the optional equipment that has been installed with the unit. Please refer to the installation instructions supplied with the accessory.

- All electrical connections and circuits are installed in compliance with and conform to the National Electrical Code and local codes which have jurisdiction.
- Wall sleeve and condensate lines are installed correctly.
- Electrical power is disconnected.
- Condenser air inlet and outlet **MUST** be clear and free of obstructions.
- Cardboard wall sleeve support and louver weatherboard are removed.

Checklist Continued

- Subbase kit or other means of structural support is required for **ALL** installations which project more than 8" (203 mm) into room.
- Unit is installed in a 18⁵/₁₆" H x 32" W x 16⁹/₁₆" D (465 x 813 x 421 mm) wall sleeve.
- Ensure that drapes, bed, bedspread, furniture, etc. **DO NOT** block either return or discharge air openings.

2

Electrical Requirements

!

WARNING

Electric shock hazard.

Turn **OFF** electric power before service or installation. All electrical connections and wiring **MUST** be installed by a qualified electrician and conform to the National Electrical Code and all local codes which have jurisdiction.

Failure to do so can result in property damage, personal injury and/or death.

Wire Size

Use **ONLY** wiring size recommended for single outlet branch circuit.

Fuse/Circuit Breaker

Use **ONLY** type and size fuse or HACR circuit breaker indicated on unit's rating plate (**see Page 4 & 5**). Proper current protection to the unit is the responsibility of the owner.

Grounding

Unit **MUST** be grounded from branch circuit through service cord to unit, or through separate ground wire provided on permanently connected units. Be sure that branch circuit or general purpose outlet is grounded.

Receptacle





The field supplied outlet must match plug on service cord and be within reach of service cord. Refer to **Table 1** for proper receptacle and fuse type. Do **NOT** alter the service cord or plug. Do **NOT** use an extension cord.

Wire Sizing

Use recommended wire size given in **Table 2** and install a single branch circuit. All wiring must comply with local and national codes. **NOTE:** Use copper conductors only.

Electrical Rating Tables

Receptacles and Fuse Types

Table 1	250V			265/277V
AMPS	15	20*	30	20
RECEPTACLE				
MFG PART NO.	Hubbell 5661 P&S 5661 GE GE4069-1 Arrow-Hart 5661	5461 5871 GE4182-1 5861	9330 5930 GE4139-3 5700	— 7621BR GE4290-3 7621
TIME-DELAY TYPE FUZE (or HACR circuit breaker)	15	20	30	20
<p>HACR – Heating, Air Conditioning, Refrigeration</p> <p>* May be used for 15 Amp applications if fused for 15 Amp</p> <p>NOTE: 265/277-volt units require use of accessory subbase DAX99SB to meet NEC and local codes.</p>				

– Continued on next page –

Electrical Rating Tables Continued



NOTE: Use Copper Conductors **ONLY**

Table 2		Wire Amp Ratings *
NAMEPLATE AMPS	AWG. Wire Size Ψ	
7.0 to 12	14	
12.1 to 16	12	
16.1 to 24	10	

AWG – American Wire Gauge
*Single Circuit from main box
 Ψ Based on copper wire at 60°C

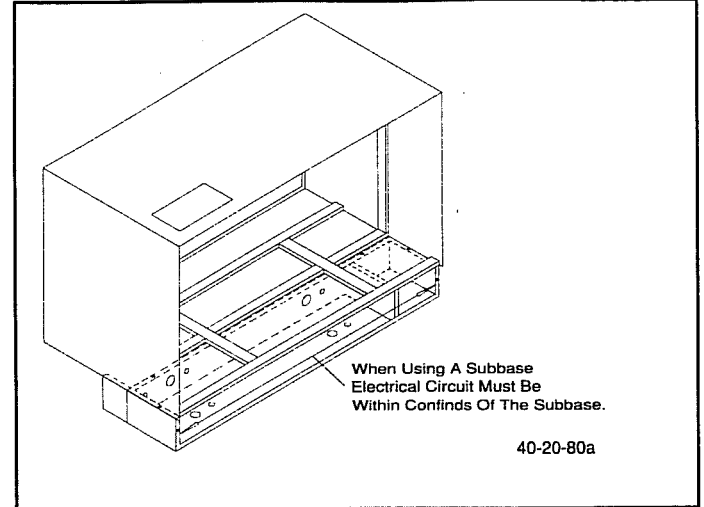

When using subbase branch circuit must be within confines of the subbase.

3

Chassis Installation

To install chassis in Sleeve:

- Remove two screws from bottom of inside closure panel. Remove and discard panel.
- Reach through sleeve and remove rear closure panel and discard.
- Tighten screws holding grille.
- Slide chassis into sleeve until bump on base pan nests behind rib in cabinet.
- Engage the hooks on the sides of front panel in the slots in the side flanges in the sleeve.
- Install filter. (See "Maintenance Procedures", Page 10 & 11)
- Plug cord (if applicable) into appropriate receptacle. Extra cord may be coiled inside front panel.

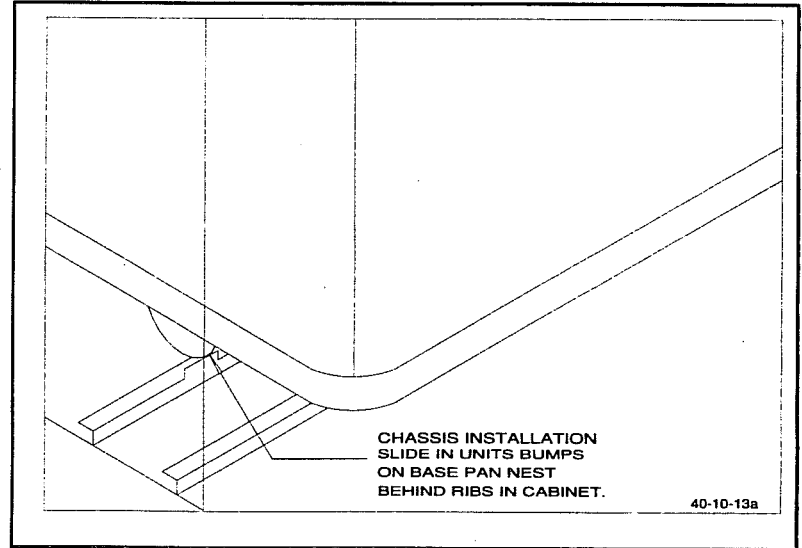

Unit Operation

4

Controls Operation

The room temperature is controlled by the temperature control knob. Once a comfortable setting is selected, no other adjustments are necessary.

Move the dial a small amount at a time in the direction you wish the temperature to go. Moving the dial more than $\frac{1}{4}$ " (6mm) at a time may over compensate and lead to an extreme hot or cold situation.

For Fresh Air

To bring fresh air into the room rotate the left hand knob clockwise to "Open"

For Air Flow and Temperature Control

Both the center and right control knobs must be rotated to the right side (Blue) for cooling or to the left side (Red) for heating.

Control	Operation
Fan Speed	Off = Turn center control knob to vertical position labeled "OFF" CAUTION: When unit turned off wait three minutes before restarting. In case of a power interruption; turn unit "Off" until power is restored for three minutes. Hi = Highest fan speed Med = Medium fan speed Lo = Lowest fan speed
Temperature Selection	For Cool - Rotate right hand knob clockwise For Heat - Rotate right hand knob counter-clockwise. Cooling will not begin if room temperature is below 60°F (16°C).

Control Panel

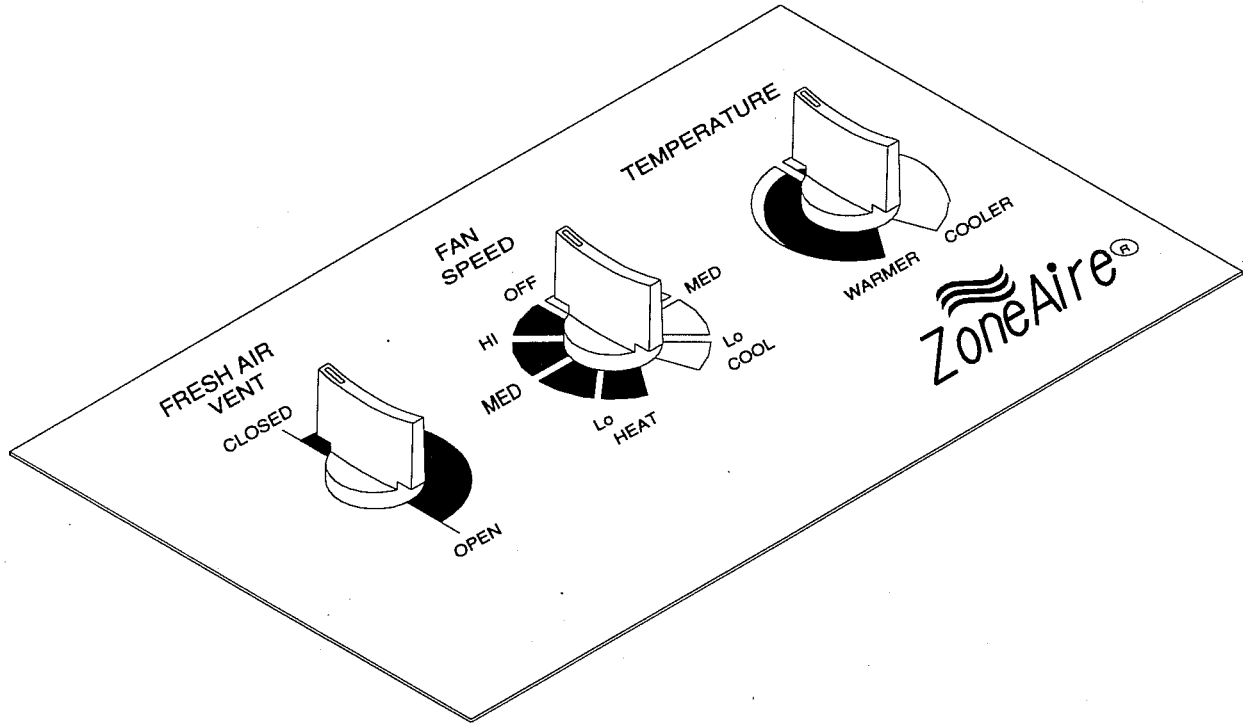

NOTE: Units are to be installed and checked for proper function by qualified service personnel **ONLY.**

Startup Checklist

5

✓ Check the following:

- Unit is installed in compliance with all codes and ordinances.
- Circuit breakers and wire sizes are correct.
- Filter clean and in place.
- All panels in place.
- Condenser air inlet and outlet free of obstructions.
- Work area clean and free of debris.
- Operate unit 20 minutes.
- Smoke and odor can occur on initial use of the heating element due to processing residue and/or oil on the element.
Leave the area serviced by the unit until it is ventilated of the smoke and odor by opening doors and windows.
- Controls operation OK.
- Owner or operator instructed on control operation and routine maintenance.
- Name and phone number of service company attached to unit or noted in telephone directory.
- Condensate drain adequate.
- Electrical cord is stored properly.

6

Routine Maintenance

- Keep air intake filter clean. A dirty filter reduces the efficiency of the system and can cause erratic performance of controls. It can also result in damage to the heating element and compressor. The unit is provided with a washable filter that can be cleaned with soap and water. Inspect and clean the filter at least once a month or more often as conditions dictate. Replace as necessary with a factory approved filter. To remove filter, reach under the front panel and pull filter from bottom of unit. To replace filter, "U" form and slide it up into opening between the front panel and the unit. Hook the edge of the filter to the unit and then position the front edge of the filter on inside of front panel.

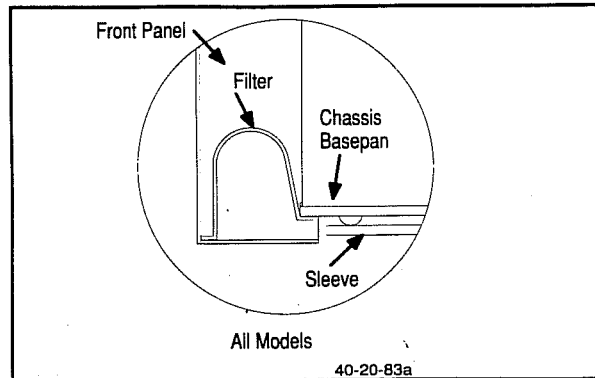

- Front panel and grille are metal parts which may be cleaned in the same manner as any painted surface.

– Continued on next page –

Routine Maintenance Continued

- Coils should be inspected periodically for build-up of lint, dirt, leaves, other debris and bent fins. Clean coils with soft brush and compressed air or vacuum. Do **NOT** use sharp objects to clean coils.
- Oiling of the fan motor annually is recommended to prolong the life of the motor. Stop unit operation, remove panel front, pull the unit out of the sleeve and remove top panel to gain access to condenser fan motor oilier ports. Add 10 drops of SAE 20 non detergent oil to each oilier port.
- In areas of heavy snow and ice accumulation, snow and ice should not be permitted to accumulate against the unit. As soon as practical after such inclement weather, clean snow and ice from around the unit and as much as possible from the filters on the unit.
- If unit is installed over the winter, be sure that the fans turn freely before turning it on.

7

Operational Practices

- Do not block air flow. Efficient operation of the unit depends on free circulation of air over the coils. Paper, leaves and other debris can reduce efficiency and cause serious damage to the compressor.
- Ensure that objects such as drapes, furniture, or plants are not blocking free air flow of unit.
- Do NOT operate unit with front panel removed or without filter.
- Keep doors and windows closed. Leaving them open will increase the workload on the unit and will result in higher operating cost and excessive condensate.
- Do NOT operate unit during construction. Construction dust can clog filter and cause permanent damage to other components.