

# 16 Series

16W (hydronic)  
16E (electric)

16E FITS 37 1/2" WIDE X 16" SLEEVE

16W FITS 41 1/2" WIDE X 16" SLEEVE

SLIDE IN REPLACEMENT FOR:

16 - American Air Filter®, Nelson Air®, Singer®,  
Remington®, Islandaire®, Applied Comfort®

AAF 16, Enersaver

PNES, ENR - McQuay®, AAF

WY - McQuay®, AAF, Islandaire®

R10 - RetroAire®



Premium, . . . meet Affordable!

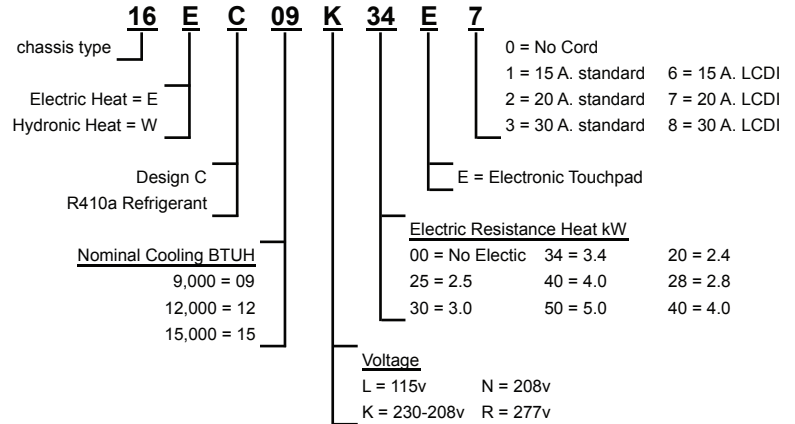

Re-engineered for 2012  
quieter! more dehumidification!

## 16WC Air Conditioner with Hydronic Heat

PERMANENTLY CONNECTED. SUB-BASE Connected. Non-LCDI cord plugs into hard-wired protected receptacle.

Model	Voltage	Hz	Min. Circuit Amps	MOP* Fuse Amps	Electrical Plug (NEMA)	Cooling					Resistance Heat			Indoor CFM HIGH*	Indoor CFM LOW*	Vent CFM	Net Wt. lbs.	Ship Wt. lbs.
						BTU/Hr.	EER	Amps	S/T	Pts./hr.	BTU/Hr.	kW	Amps					
16WC09L00E2	115	60	13	15	#5-20P	9600	10	10	0.78	2.0	N/A	N/A	N/A	310	265	90	118	126
16WC12L00E2	"	"	16.2	20	#5-20P	11700	9.2	12.6	0.7	3.3	N/A	N/A	N/A	360	310	"	"	"
16WC09N00E2	208	"	6.2	15	#6-20P	9600	10	5.1	0.78	2.0	N/A	N/A	N/A	300	250	"	"	"
16WC12N00E2	"	"	8.1	"	"	11600	9.2	6.6	0.7	2.8	N/A	N/A	N/A	350	300	"	"	"
16WC15N00E2	"	"	9.8	"	"	14000	8.8	8.3	0.68	4.3	N/A	N/A	N/A	"	"	"	"	"
16WC09K00E2	230 - 208	"	6.2	15	#6-20P	9600	10	4.9/5.1	0.8	1.8	N/A	N/A	N/A	325/300	290/250	"	"	"
16WC12K00E2	"	"	8.1	"	"	11600	9.2	6.3/6.6	0.75	2.8	N/A	N/A	N/A	370/350	325/300	"	"	"
16WC15K00E2	"	"	9.8	"	"	14000	8.8	7.9/8.3	0.68	4.3	N/A	N/A	N/A	370/350	325/300	"	"	"
16WC09R00E2	277	"	5.7	15	#7-20P	9600	10	4	0.8	1.8	N/A	N/A	N/A	360	310	"	"	"
16WC12R00E2	"	"	6.8	"	"	11700	9.2	5.3	0.75	2.8	N/A	N/A	N/A	"	"	"	"	"
16WC15R00E2	"	"	8.4	"	"	14200	8.8	6.6	0.68	4.3	N/A	N/A	N/A	"	"	"	"	"

\*Time Delay Fuse or HCAR Circuit Breaker ---- \*Dry Coil

Model	Voltage	Hz	Hot Water Heat HIGH SPEED	Hot Water Heat LOW SPEED	Water Flow Rate	Coil Pressure Drop (HIGH SPEED)	Steam Heat HIGH SPEED	Steam Heat LOW SPEED	Heating Current
			BTU/Hr.	BTU/Hr.		USGPM	Ft of Water	BTU/Hr.	
16WC09L00E2	115	60	17200	16100	1.8	1.8	21100	19600	<1
16WC12L00E2	"	"	18500	17400	1.9	1.9	22600	21100	"
16WC09N00E2	208	"	17000	15600	1.7	1.6	20800	19000	"
16WC12N00E2	"	"	18300	17200	1.9	1.8	22300	20800	"
16WC15N00E2	"	"	18300	17200	1.9	1.8	22300	20800	"
16WC09K00E2	230 - 208	"	17600/17000	16800/15600	1.8 - 1.7	1.8 - 1.6	21500/20800	20500/19000	"
16WC12K00E2	"	"	18800/18300	17700/17200	1.9 - 1.9	2.0 - 1.8	22900/22300	21600/20800	"
16WC15K00E2	"	"	18800/18300	17700/17200	1.9 - 1.9	2.0 - 1.8	22900/22300	21600/20800	"
16WC09R00E2	277	"	18500	17400	1.9	1.8	22600	21100	"
16WC12R00E2	"	"	"	"	"	"	"	"	"
16WC15R00E2	"	"	"	"	"	"	"	"	"

Maximum Steam Pressure: 2 psig ---- Steam ratings based on conditions of 70°F entering air, and 2 psig steam pressure with heat output automatically adjusting for blower speed. Maximum Water Temperature: 210°F ---- HIGH SPEED Water ratings based on ASHRAE/AHRI conditions of 70°F entering air, 200°F entering water and 180°F leaving water temperatures. LOW SPEED Water ratings based on water flow rate set for HIGH SPEED rating condition operating point.



### Electronic Touchpad Controls

- on-chassis touchpad with large LED readout
- switchable to 24v remote thermostats - EMS ready
- two speed room fan control
- electronic temperature limiting
- fresh air supply door provided

Distributed By:

Premium

www.ptacs.com

Affordable

16EC Air Conditioner with Electric Resistance Heat

PERMANENTLY CONNECTED. SUB-BASE Connected. Non-LCDI short cord plugs into hard-wired protected receptacle in Sub-base.

Model	Voltage	Hz	Min. Circuit Amps	MOP* Fuse Amps	Electrical Plug (NEMA)	Cooling					Resistance Heat			Indoor CFM HIGH°	Indoor CFM LOW°	Vent** CFM	Net Wt. lbs.	Ship Wt. lbs.
						BTU/Hr.	EER	Amps	S/T	Pts./hr.	BTU/Hr.	kW	Amps					
16EC09L00E2	115	60	13	15	#5-20P	9600	10	10	0.78	2.0	N/A	N/A	N/A	325	275	90	118	126
16EC12L00E2	"	"	16.2	20	#5-20P	11600	9.2	12.6	0.7	3.3	N/A	N/A	N/A	"	"	"	"	"
16EC09N00E2	208	"	6.2	15	#6-20P	9600	10	5.1	0.78	2.0	N/A	N/A	N/A	315	260	"	"	"
16EC09N20E2	"	"	13	"	"	"	"	"	"	"	7300	2.0	10.4	"	"	"	"	"
16EC09N28E2	"	"	17.4	20	"	"	"	"	"	"	9900	2.8	13.9	"	"	"	"	"
16EC09N41E2	"	"	25.3	30	"	"	"	"	"	"	14300	4.1	20.2	"	"	"	"	"
16EC12N00E2	"	"	8.1	20	"	11600	9.2	6.6	0.7	2.8	N/A	N/A	N/A	"	"	"	"	"
16EC12N20E2	"	"	13	"	"	"	"	"	"	"	7300	2.0	10.4	"	"	"	"	"
16EC12N28E2	"	"	17.4	"	"	"	"	"	"	"	9900	2.8	13.9	"	"	"	"	"
16EC12N41E2	"	"	25.3	30	"	"	"	"	"	"	14300	4.1	20.2	"	"	"	"	"
16EC15N00E2	"	"	9.8	20	"	14000	8.8	8.3	0.68	4.3	N/A	N/A	N/A	"	"	"	"	"
16EC15N20E2	"	"	13	"	"	"	"	"	"	"	7300	2.0	10.4	"	"	"	"	"
16EC15N28E2	"	"	17.4	"	"	"	"	"	"	"	9900	2.8	13.9	"	"	"	"	"
16EC15N41E2	"	"	25.3	30	"	"	"	"	"	"	14300	4.1	20.2	"	"	"	"	"
16EC09K00E2	230 - 208	"	6.2	20	#6-20P	9600	10	5.1	0.78	2.0	N/A	N/A	N/A	345/315	300/260	"	"	"
16EC09K25E2	"	"	14.3	"	"	"	"	"	"	"	8900/7300	2.5/2.1	11.4/10.4	"	"	"	"	"
16EC09K34E2	"	"	19.2	"	"	"	"	"	"	"	12000/9900	3.4/2.8	15.3/13.9	"	"	"	"	"
16EC09K50E3	"	"	27.9	30	#6-30P	"	"	"	"	"	17400/14300	5/4.1	22.3/20.2	"	"	"	"	"
16EC12K00E2	"	"	8	20	#6-20P	11600	9.2	6.6	0.7	2.8	N/A	N/A	N/A	"	"	"	"	"
16EC12K25E2	"	"	13.3	"	"	"	"	"	"	"	8900/7300	2.5/2.1	11.4/10.4	"	"	"	"	"
16EC12K34E2	"	"	19.2	"	"	"	"	"	"	"	12000/9900	3.4/2.8	15.3/13.9	"	"	"	"	"
16EC12K50E3	"	"	27.9	30	#6-30P	"	"	"	"	"	17400/14300	5/4.1	22.3/20.2	"	"	"	"	"
16EC15K00E2	"	"	9.7	20	#6-20P	14000	8.8	8.3	0.68	4.3	N/A	N/A	N/A	"	"	"	"	"
16EC15K25E2	"	"	14.3	"	"	"	"	"	"	"	8900/7300	2.5/2.1	11.4/10.4	"	"	"	"	"
16EC15K34E2	"	"	19.2	"	"	"	"	"	"	"	12000/9900	3.4/2.8	15.3/13.9	"	"	"	"	"
16EC15K50E3	"	"	27.9	30	#6-30P	"	"	"	"	"	17400/14300	5/4.1	22.3/20.2	"	"	"	"	"
16EC09R00E2	277	"	5.7	15	#7-20P	9600	10	4.3	0.78	2.0	N/A	N/A	N/A	380	335	"	"	"
16EC09R20E2	"	"	9.9	"	"	"	"	"	"	"	7200	2.0	8.0	"	"	"	"	"
16EC09R30E2	"	"	14.4	"	"	"	"	"	"	"	10600	3.0	11.6	"	"	"	"	"
16EC09R40E2	"	"	19	20	"	"	"	"	"	"	14000	4.0	15.2	"	"	"	"	"
16EC12R00E2	"	"	6.8	15	"	11600	9.2	5.7	0.7	2.8	N/A	N/A	N/A	"	"	"	"	"
16EC12R20E2	"	"	9.9	"	"	"	"	"	"	"	7200	2.0	8.0	"	"	"	"	"
16EC12R30E2	"	"	14.4	"	"	"	"	"	"	"	10600	3.0	11.6	"	"	"	"	"
16EC12R40E2	"	"	19	20	"	"	"	"	"	"	14000	4.0	15.2	"	"	"	"	"
16EC15R00E2	"	"	8.4	15	"	14000	8.8	6.9	0.68	4.3	N/A	N/A	N/A	"	"	"	"	"
16EC15R20E2	"	"	9.9	"	"	"	"	"	"	"	7200	2.0	8.0	"	"	"	"	"
16EC15R30E2	"	"	14.4	"	"	"	"	"	"	"	10600	3.0	11.6	"	"	"	"	"
16EC15R40E2	"	"	19	20	"	"	"	"	"	"	14000	4.0	15.2	"	"	"	"	"

\*Time Delay Fuse or HCAR Circuit Breaker ---- °Dry Coil ---- 277v models are permanently connected using 20amp non-LCDI cords.

CORD-CONNECTED. LCDI full-length Cord for connection to remote receptacle.

Model	Voltage	Hz	Min. Circuit Amps	MOP* Fuse Amps	Electrical Plug (NEMA)	Cooling					Resistance Heat			Indoor CFM HIGH°	Indoor CFM LOW°	Vent** CFM	Net Wt. lbs.	Ship Wt. lbs.
						BTU/Hr.	EER	Amps	S/T	Pts./hr.	BTU/Hr.	kW	Amps					
16EC09L00E6	115	60	13	15	#5-15P	9600	10	10	0.78	2.0	N/A	N/A	N/A	325	275	90	118	126
16EC09L00E7	"	"	"	20	#5-20P	9600	10	10	0.78	2.0	N/A	N/A	N/A	"	"	"	"	"
16EC12L00E7	"	"	16.2	20	#5-20P	11600	9.5	12.6	0.7	3.3	N/A	N/A	N/A	"	"	"	"	"
16EC09K00E6	230 - 208	"	6.2	15	#6-15P	9600	10	5.1	0.78	2.0	N/A	N/A	N/A	345/315	300/260	"	"	"
16EC09K00E7	"	"	"	20	#6-20P	"	"	"	"	"	"	"	"	"	"	"	"	"
16EC09K25E6	"	"	14.3	15	#6-15P	"	"	"	"	"	8900/7300	2.5/2.1	11.4/10.4	"	"	"	"	"
16EC09K25E7	"	"	"	20	#6-20P	"	"	"	"	"	8900/7300	2.5/2.1	11.4/10.4	"	"	"	"	"
16EC09K34E7	"	"	19.2	20	#6-20P	"	"	"	"	"	12000/9900	3.4/2.8	15.3/13.9	"	"	"	"	"
16EC09K34E8	"	"	"	30	#6-30P	"	"	"	"	"	12000/9900	3.4/2.8	15.3/13.9	"	"	"	"	"
16EC09K50E8	"	"	27.9	30	#6-30P	"	"	"	"	"	17400/14300	5/4.1	22.3/20.2	"	"	"	"	"
16EC12K00E6	"	"	8	15	#6-15P	11600	9.2	6.6	0.7	2.8	N/A	N/A	N/A	"	"	"	"	"
16EC12K00E7	"	"	"	20	#6-20P	11600	9.2	6.6	0.7	2.8	N/A	N/A	N/A	"	"	"	"	"
16EC12K25E6	"	"	13.3	15	#6-15P	"	"	"	"	"	8900/7300	2.5/2.1	11.4/10.4	"	"	"	"	"
16EC12K25E7	"	"	"	20	#6-20P	"	"	"	"	"	8900/7300	2.5/2.1	11.4/10.4	"	"	"	"	"
16EC12K34E7	"	"	19.2	20	#6-20P	"	"	"	"	"	12000/9900	3.4/2.8	15.3/13.9	"	"	"	"	"
16EC12K34E8	"	"	"	30	#6-30P	"	"	"	"	"	12000/9900	3.4/2.8	15.3/13.9	"	"	"	"	"
16EC12K50E8	"	"	27.9	30	#6-30P	"	"	"	"	"	17400/14300	5/4.1	22.3/20.2	"	"	"	"	"
16EC15K00E6	"	"	9.7	15	#6-15P	14000	8.8	8.3	0.68	4.3	N/A	N/A	N/A	"	"	"	"	"
16EC15K00E7	"	"	"	20	#6-20P	14000	8.8	8.3	0.68	4.3	N/A	N/A	N/A	"	"	"	"	"
16EC15K25E6	"	"	14.3	15	#6-15P	"	"	"	"	"	8900/7300	2.5/2.1	11.4/10.4	"	"	"	"	"
16EC15K25E7	"	"	"	20	#6-20P	"	"	"	"	"	8900/7300	2.5/2.1	11.4/10.4	"	"	"	"	"
16EC15K34E7	"	"	19.2	20	#6-20P	"	"	"	"	"	12000/9900	3.4/2.8	15.3/13.9	"	"	"	"	"
16EC15K34E8	"	"	"	30	#6-30P	"	"	"	"	"	12000/9900	3.4/2.8	15.3/13.9	"	"	"	"	"
16EC15K50E8	"	"	27.9	30	#6-30P	"	"	"	"	"	17400/14300	5/4.1	22.3/20.2	"	"	"	"	"

\*Time Delay Fuse or HCAR Circuit Breaker ---- °Dry Coil

Specifications Subject to Change Without Notice

All brands and product names are trademarks or registered trademarks of their respective owners.

