

# WME09L Compact Packaged Terminal Air Conditioner (PTAC)

# Installation Operation and Maintenance Manual

## RECORD YOUR MODEL AND SERIAL NUMBER HERE

If you should require service or call with a question, please have the following information available:

1. COMPLETE MODEL AND SERIAL NUMBER. This information is found on a plate located in the air outlet area, which you can see when plastic front grille is removed (see figure 4, for removal).
2. PURCHASE DATE from sales slip.
3. Note that this information should also be recorded on your warranty registration card.

Model Number \_\_\_\_\_

Serial Number \_\_\_\_\_

Purchase Date \_\_\_\_\_

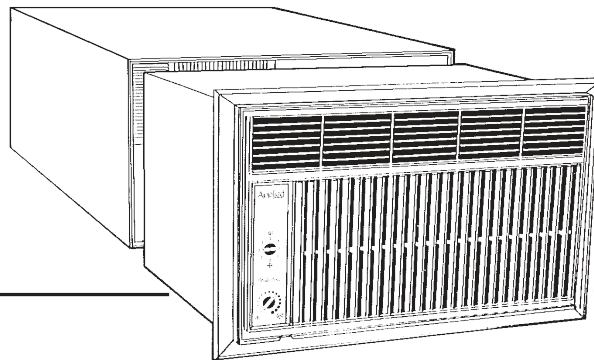

NOTE: Retain this manual for future reference

## IMPORTANT...

*This manual tells how to install, use and care for your air conditioner, as well as how to get the most efficient cooling operation.*

### BEFORE YOU USE YOUR AIR CONDITIONER

*It is your responsibility to make sure that your air conditioner*

- has been properly installed;
- is the right size for the area to be cooled;
- is properly connected to electricity; is properly electrically grounded;
- is properly maintained
- after installing your air conditioner be sure your unit is "off" before plugging it in. See page 4 for control instructions.
- is being used as designed. Do not operate in a corrosive or extremely dirty atmosphere or at below normal ambient temperature.
- does not have rear louvres restricted since unit requires proper air circulation to operate.

## **I M P O R T A N T**

**READ AND SAVE THESE INSTRUCTIONS INSTALLATION  
AND WIRING MUST BE IN ACCORDANCE WITH CEC,  
NEC AND LOCAL ELECTRICAL CODES.**

## ELECTRICAL REQUIREMENTS

PLUG THE UNIT INTO A STANDARD 115 VOLT 60 HERTZ GROUNDED WALL RECEPTACLE. USE ONLY A 15 AMP TIME DELAY FUSE OR HACR CIRCUIT BREAKER. RECEPTACLE WIRING #14 GAUGE MIN.

The Air Conditioner is equipped with a three-wire cord and three prong plug. **ELECTRICAL GROUND IS REQUIRED ON THIS UNIT.** Do not alter unit power supply or plug. A separate circuit serving only this unit is to be provided. Do not use an extension cord. A damaged cord must not be repaired - it must be replaced.

The unit will not operate on direct current. Electrical specifications are shown on the Model and Serial plate located inside the plastic front grille (observe local codes).

## INSTALLATION INSTRUCTIONS - MODEL WME

To help eliminate any installation problems and to help assure trouble-free performance of your new air conditioner, read these instructions before installing this unit.

Because this air conditioner weighs approximately 110 pounds (49.9 kg), it is recommended that you have someone help you install your new unit and that you both use proper lifting techniques to avoid personal injury.

The PTAC chassis must be used with Wall Sleeve Model CSLV-1. If replacing the chassis-only, check the condition of the previously installed CSLV-1 wall sleeve. Be sure the bearing surface will still support the weight of the unit, and that the sleeve is fastened well in the wall opening. The wall sleeve must be installed **LEVEL** in all directions in the wall opening, as there is a built-in slope in the bottom of the wall sleeve to ensure proper drainage of the PTAC chassis and wall sleeve.

**CAUTION:** Be sure the wall sleeve or air conditioner does not fall during installation.  
Handle the air conditioner with care. Watch out for the sharp metal fins on the front and rear coils.  
Do not use water condensate for drinking purposes - it is not sanitary.

***THIS APPLIANCE MUST BE INSTALLED ACCORDING TO ALL APPLICABLE CODES AND ORDINANCES.***

## NOTICE

Before installing the air conditioner in the Original Equipment Sleeve, to obtain the rated energy efficiency and performance for this unit, the additional seal strips provided with the unit must be applied to the rear of the chassis as shown (See figure 2), prior to installation in the wall sleeve. Do not allow any seal to block the overflow notch. Lift and slide PTAC chassis into wall sleeve, pushing it back until it butts up against rear of sleeve/outdoor grille.

Make certain the PTAC chassis is centered in the wall sleeve and the wall sleeve is level in all directions. There is a positive slope in the bottom panel of the CSLV-1 Original Equipment Wall Sleeve (identified being 23" wide x 15 9/32" high) that will give the correct slope to the air conditioner chassis for proper drainage when it is slid into the wall sleeve.

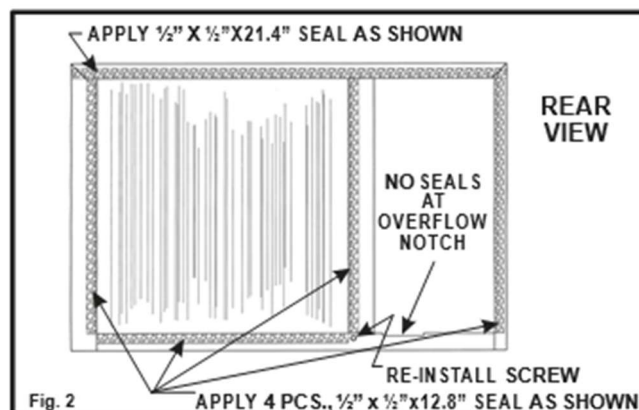

**INSTALLING CHASSIS SEALS**

## WALL SLEEVE SEAL

Install seal strip that is supplied with sleeve (5/8" x 5/8" x 76" long), between air conditioner and sleeve on all four sides. (See Figure 3)

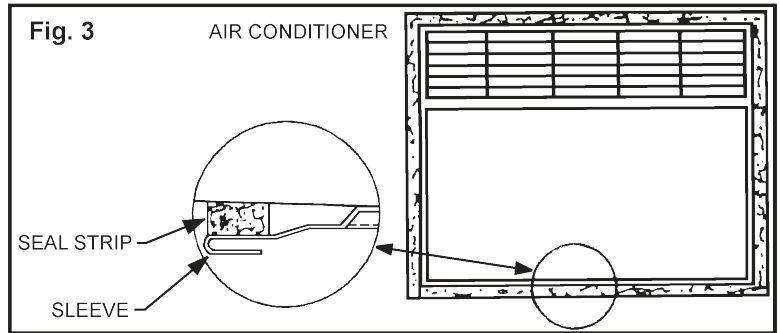

## DECORATOR TRIM FRAME

(NOT SUPPLIED)

Replacement situations will already have the decorative Trim Frame in use and installed as shown in figure 4. Replace Plastic Front Grille as indicated in figure 4. For new installations order the Decorative Trim Frame Kit Model Number RAX99TRA1.

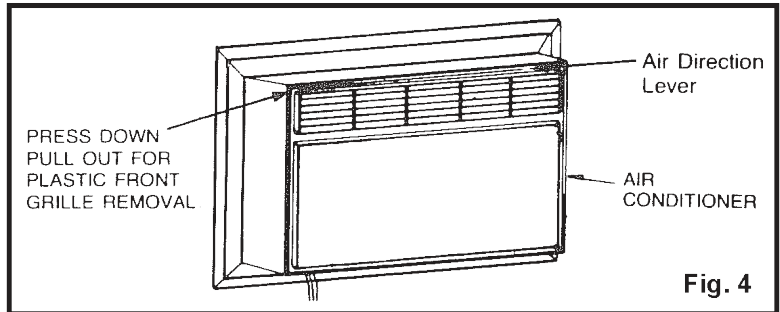

## REGULAR MAINTENANCE

### CAUTION:

Before doing any maintenance, disconnect power cord. Make sure water does not get into motor or electrical connections. Use gloves to avoid cuts from the sharp coil fins. Do not use cleaning fluids, solvents, abrasive cleaners or strong detergents; they may damage the parts.

### EVERY MONTH DURING OPERATING PERIOD:

Remove plastic front panel by pressing downward and pulling towards you. See figure 4. Then remove filter and hand wash. Dry before placing back in unit.

### EVERY YEAR:

Remove the air conditioner from the wall sleeve. Remove the air conditioner outer cabinet casing and clean the coil fins. Clean cabinet and grille using soft cloth dampened in a mild detergent solution.

## BEFORE YOU CALL A SERVICEMAN, CHECK THE FOLLOWING:

- |                        |   |
|------------------------|---|
| NOT COOLING PROPERLY?  | <input type="checkbox"/> Is the filter clean?   |
|                        | <input type="checkbox"/> Any blockage in front of unit? (Drapes)  |
|                        | <input type="checkbox"/> Is thermostat set cold enough?   |
|                        | <input type="checkbox"/> Is function switch on the "cool" ❄️ position (standard control units) or the wall thermostat set to "cool" (24V. Remote thermostat units). |
| ICED UP INSIDE?        | <input type="checkbox"/> Did unit operate overnight on "low" (1) fan speed with thermostat set "hi"?  |
|                        | <input type="checkbox"/> Is your filter dirty?  |
| WILL NOT RUN OR NOISY? | <input type="checkbox"/> If noisy, check for loose mounting/windows.  |
|                        | <input type="checkbox"/> If fuse is blown, you should be using Fusetron (time-delay) type.  |
|                        | <input type="checkbox"/> Check wall receptacle with another appliance.  |

## IF SERVICE IS REQUIRED

Contact the dealer from whom your unit was purchased for the name of and address of the nearest authorized service depot. For further assistance contact customer service at **Applied Comfort Products, 1210 Balmoral Road, Cambridge, Ontario N1T 1A5. Telephone (519) 740-3600, Fax (519) 740-1666.**

# OPERATING INSTRUCTIONS

## VERSION "S", STANDARD UNIT - MOUNTED CONTROLS

Be sure your air conditioner is "off" before plugging it in. "0" or "off" -- position shuts off entire unit. See Figure 5.

### TO START YOUR AIR CONDITIONER

#### 1. FOR COOLING ❄️

Choose either High (setting "3"), Medium (setting "2") or Low (setting "1") fan speed. The Fan will run at all times when air conditioner is switched "On".

#### SELECT:

Low fan speed "1" for quiet cooling with gentle air circulation.

Medium fan speed "2" for moderate cooling and air movement.

High fan speed "3" for maximum cooling and air movement.

#### 2. FOR AIR CIRCULATION 🌀 (without cooling)

#### SELECT:

Low fan speed "1" for quiet, gentle air circulation.

Medium fan speed "2" for moderate air circulation.

High fan speed "3" for maximum air circulation.

#### **CAUTION**

If you turn your air conditioner "OFF", wait at least two minutes before turning it back "ON", or you may blow a fuse.

**3. TURN THE THERMOSTAT CONTROL** to the "maximum" cooling position (full clockwise). This starts the compressor, as long as the room and outside air temperature are not below normal. When the room becomes comfortable, slowly turn the knob counterclockwise (to a lower setting), until you hear the compressor stop (the fan will continue to circulate air).

To automatically maintain the temperature selected, leave the thermostat control knob in this position. When the room temperature rises sufficiently, the compressor will automatically turn on and begin cooling again.

NOTE: Turning the knob clockwise produces greater cooling and turning the knob counterclockwise produces less cooling.

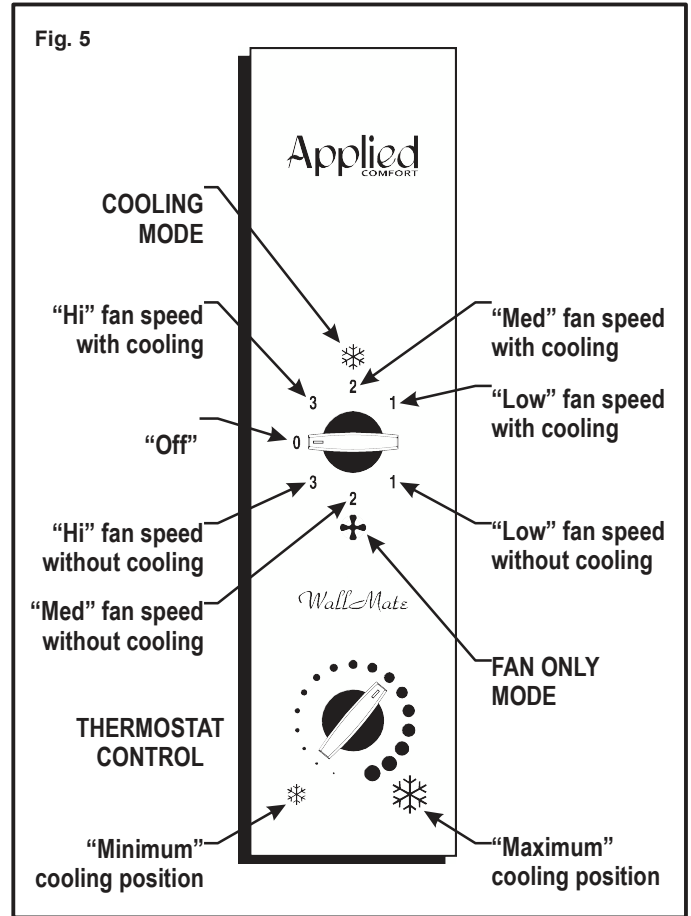

#### 4. CHANGING AIR DIRECTION

The louvers in the grille area at the top of the air conditioner control the direction of the cooled air. The rear vertical louvers in the grille can be adjusted left or right or straight ahead. The front louvers are fixed and directed upward. SIMPLY MOVE THE LEVER IN THE DIRECTION YOU WANT THE AIR TO GO. See Figure 6.

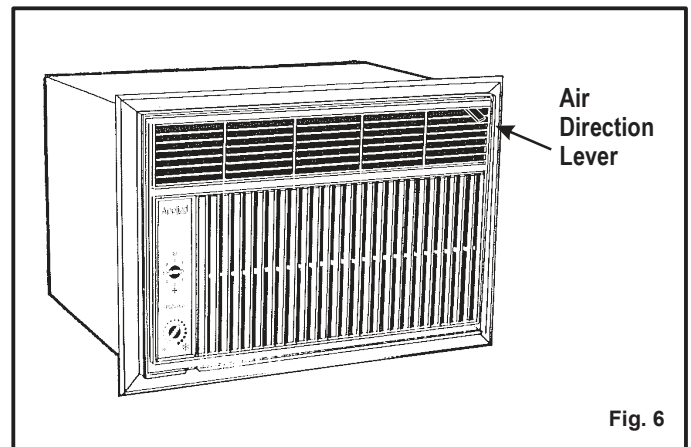

## VERSION 'R', 24 VAC REMOTE WALL THERMOSTAT OPTION COOLING-ONLY, NO HEAT

### GENERAL:

This supplement contains information specific to 24 Volt AC remote wall thermostat-ready WMC series models. Please also refer to the preceding sections of the general Installation Operation and Maintenance Instructions for the unit.

### THERMOSTAT SELECTION:

Superior control of room temperature is achieved by using a wall thermostat mounted at a distance from the unit. Any standard cooling-only or single-stage 24 volt heat/cool thermostat intended to control a gas or electric heating unit with cooling can be made to work with the unit; this includes auto changeover and electronic thermostats.

A room thermostat is basically a switch that directs 24 volt power from its "R" terminal to its W, Y, and G terminals, according to the function being demanded by the user. The WMC unit is a cooling-only unit, so the terminal marked "W" will not be used. If a basic thermostat is a switch, it does not consume power, and normally requires only a 3 thermostat wire hookup. However, electronic thermostats need to be powered somehow; some use batteries or power scavenging, but some need 24 volt AC power to be provided from the unit's transformer via the "C" terminal, in addition to the R terminal, especially if its display is backlit. If your thermostat requires connection to the "C" terminal, it will require 4 thermostat wires to be run in the wall. Hook up your thermostat accordingly.

### THERMOSTAT LOCATION:

Proper functioning of the remote thermostat depends on accurate room temperature sensing. Be conscious of locating the thermostat where the temperature near the thermostat may not be representative of room temperature. Do not install the thermostat where it will be subjected to direct sunlight, other sources of heat, or cold drafts, including discharge air from the supply register. A common mistake is not sealing the hole in the wall where the thermostat cable passes into the thermostat body. Air from behind the wall can drastically affect the temperature sensed by the thermostat.

### THERMOSTAT CONNECTION:

Follow the steps in the basic Installation Instructions and then proceed as follows:

Remove the plastic front grille by pressing it downward and then pulling it toward you. Once removed, it will expose the 24 VAC terminal strip with the markings R, W, Y, G, and C at the corresponding wire binding screw locations where the thermostat wiring connections will be made. Route the thermostat wire bundle up through the 3/8" plastic clamp on the front of the control box to guide wiring away from any sharp edges. Make the connections from the thermostat to the terminal strip in the unit as follows:

R to R, Y to Y, G to G (W is not used).  
C to C, if C is required by the thermostat to operate.

#### **IMPORTANT**

Do not connect any thermostat wire to Terminal C on the terminal strip unless it will connect to Terminal C at the wall thermostat. Failure to do so will result in a transformer burnout.

Re-install the plastic front grille. Set the fan speed control to '0' (OFF) and then plug in the unit.

### OPERATING INSTRUCTIONS

#### THERMOSTAT OPERATION:

The wall thermostat controls the cycling rate in cooling mode, and whether the fan is in intermittent or continuous operation. Once a comfortable setting is established, no other adjustments are necessary except for fan speed, which is adjusted by the rotary switch at the unit.

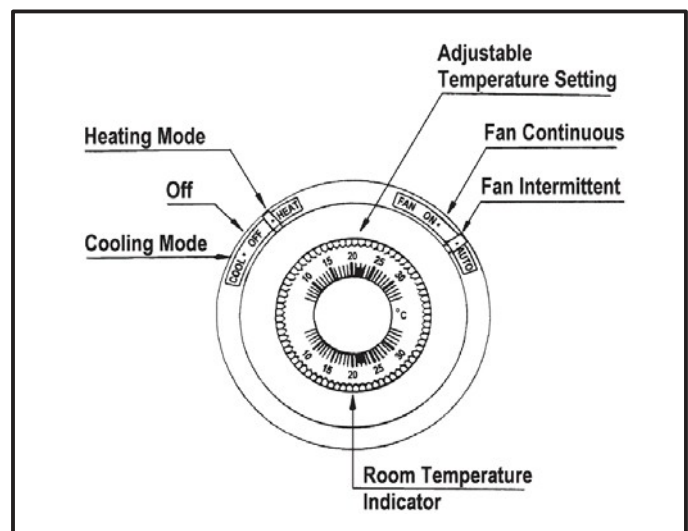

## WALL THERMOSTAT OPERATION

<b>Heat (Not Used)</b>	Sets the unit into heating mode. Will initiate heating when the room temperature falls below the set point. (Not applicable)
<b>Off</b>	Disables cooling mode, but still allows control of fan.
<b>Cool</b>	Sets the unit into cooling mode. Initiates cooling when the room temperature rises above the set point.
<b>Auto (Not Used)</b>	Found on automatic changeover thermostats only. Allows the thermostat to decide whether it should be in the heating or cooling mode. (Not applicable)
<b>Adjustable Temperature Setting</b>	Establishes the "set point", or desired room temperature.
<b>Fan On</b>	Synonymous with "Fan Continuous". Fan will continue to run after the cooling has cycled off. Fan will not run if mode switch is in Off position.
<b>Fan Auto</b>	Synonymous with "Fan Intermittent". Fan will cycle on and off with the cooling cycle, and will not operate between cycles.

## ROTARY SWITCH

The rotary switch can be rotated to the left or to the right of the "Off" position - operation will be the same. Cooling output is affected by fan speed. The settings are addressed in the following table:

### ROTARY SWITCH OPERATION

<b>Off "0"</b>	Unit will not respond to any commands from the remote thermostat. 24 volts continues to be supplied to the thermostat to keep programs in electronic thermostats intact. To completely de-energize the thermostat, the power cord must be unplugged.
<b>Fan "3"</b>	High Speed. Selects highest fan speed for maximum cooling capacity, maximum airflow, and hence maximum air circulation.
<b>Fan "2"</b>	Medium Speed. Selects medium fan speed for a slightly reduced cooling capacity, at midrange airflow, and operation at a reduced sound level.
<b>Fan "1"</b>	Low Speed. Selects lowest fan speed for decent cooling capacity, maximum air dehumidification and operation at the lowest sound level.

## UNIT MOUNTED CONTROLS

### **IMPORTANT**

If the compressor is running in cooling mode, and then the unit is switched off, wait at least three minutes before switching the unit back on. This avoids cycling the compressor overload switch. Similarly, if the power has been interrupted, it is recommended that the unit be switched off and not switched on again until power has been restored for at least 3 minutes.

### **NOTE:**

The unit uses time delay relays for controlling commands from the wall thermostat. Therefore, please be patient when switching from one function to another, as the unit does not respond quickly to thermostat commands.

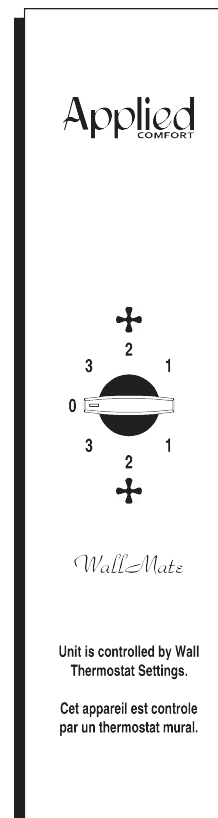

## **SERVICE/REPAIR INFORMATION:**

Service and repairs shall be completed by authorized service personnel.

Prior to beginning work on systems containing FLAMMABLE REFRIGERANTS, safety checks are necessary to ensure that the risk of ignition is minimized.

Work shall be undertaken under a controlled procedure to minimize the risk of a flammable gas or vapour being present while the work is being performed.

All maintenance staff and others working in the local area shall be instructed on the nature of the work being carried out. Work in confined spaces shall be avoided.

The area shall be checked with an appropriate refrigerant detector prior to and during work, to ensure the technician is aware of potentially toxic or flammable atmospheres. Ensure that the leak detection equipment being used is suitable for use with all applicable refrigerants, i.e. non-sparking, adequately sealed or intrinsically safe.

If any hot work is to be conducted on the refrigerating equipment or any associated parts, appropriate fire extinguishing equipment shall be available to hand. Have a dry powder or CO<sub>2</sub> fire extinguisher adjacent to the charging area.

No person carrying out work in relation to a REFRIGERATING SYSTEM which involves exposing any pipe work shall use any sources of ignition in such a manner that it may lead to the risk of fire or explosion. All possible ignition sources, including cigarette smoking, should be kept sufficiently far away from the site of installation, repairing, removing and disposal, during which refrigerant can possibly be released to the surrounding space. Prior to work taking place, the area around the equipment is to be surveyed to make sure that there are no flammable hazards or ignition risks. "No Smoking" signs shall be displayed.

Where electrical components are being changed, they shall be fit for the purpose and to the correct specification. At all times the manufacturer's maintenance and service guidelines shall be followed. If in doubt, consult the manufacturer's technical department for assistance. The following checks shall be applied to installations using FLAMMABLE REFRIGERANTS:

- The actual REFRIGERANT CHARGE is in accordance with the room size within which the refrigerant containing parts are installed.
- The ventilation machinery and outlets are operating adequately and are not obstructed.
- If an indirect refrigerating circuit is being used, the secondary circuit shall be checked for the presence of refrigerant.
- Marking to the equipment continues to be visible and legible. Markings and signs that are illegible shall be corrected.
- Refrigerating pipe or components are installed in a position where they are unlikely to be exposed to any substance which may corrode refrigerant containing components, unless the components are constructed of materials which are inherently resistant to being corroded or are suitably protected against being so corroded.

Repair and maintenance to electrical components shall include initial safety checks and component inspection procedures. If a fault exists that could compromise safety, then no electrical supply shall be connected to the circuit until it is satisfactorily dealt with. If the fault cannot be corrected immediately but it is necessary to continue operation, an adequate temporary solution shall be used. This shall be reported to the owner of the equipment, so all parties are advised.

Initial safety checks shall include:

- that capacitors are discharged: this shall be done in a safe manner to avoid possibility of sparking.
- that no live electrical components and wiring are exposed while charging, recovering or purging the system.
- that there is continuity of earth bonding.

### **1. VENTILATED AREAS**

Ensure that the area is open or that it is adequately ventilated before breaking into the system or conducting any hot work. A degree of ventilation shall continue during the period that the work is carried out. The ventilation should safely disperse any released refrigerant and preferably expel it externally into the atmosphere.

## 2. REPAIRS

During repairs to sealed components, all electrical supplies shall be disconnected from the equipment being worked upon prior to any removal of sealed covers, etc. If it is necessary to have an electrical supply to equipment during servicing, then a permanent operating form of leak detection shall be located at the most critical point to warn of a potentially hazardous situation.

Particular attention shall be paid to the following to ensure that by working on electrical components, the casing is not altered in such a way that the level of protection is affected. This shall include damage to cables, excessive number of connections, terminals not made to original specification, damage to seals, incorrect fitting of glands, etc.

Ensure that the apparatus is mounted securely.

Ensure that seals or sealing materials have not degraded to the point that they no longer serve the purpose of preventing the ingress of flammable atmospheres. Replacement parts shall be in accordance with the manufacturer's specifications.

Do not apply any permanent inductive or capacitance loads to the circuit without ensuring that this will not exceed the permissible voltage and current permitted for the equipment in use. Intrinsically safe components are the only types that can be worked on while live in the presence of a flammable atmosphere. The test apparatus shall be at the correct rating. Replace components only with parts specified by the manufacturer. Other parts may result in the ignition of refrigerant in the atmosphere from a leak.

**NOTE:** The use of silicon sealant can inhibit the effectiveness of some types of leak detection equipment. Intrinsically safe components do not have to be isolated prior to working on them.

## 3. CABLING

Check that cabling will not be subject to wear, corrosion, excessive pressure, vibration, sharp edges or any other adverse environmental effects. The check shall also consider the effects of aging or continual vibration from sources such as compressors or fans.

## 4. DETECTION

Under no circumstances shall potentially sources of ignition be used in the searching for or detection of refrigerant leaks. A halide torch (or any other detector using a naked flame) shall not be used. The following leak detection methods are deemed acceptable for all refrigerant systems. Electronic leak detectors may be used to detect refrigerant leaks but, in the case of FLAMMABLE REFRIGERANTS, the sensitivity may not be adequate or may need re-calibration. (Detection equipment shall be calibrated in a refrigerant-free area.) Ensure that the detector is not a potential source of ignition and is suitable for the refrigerant used. Leak detection equipment shall be set at a percentage of the LFL of the refrigerant and shall be calibrated to the refrigerant employed, and the appropriate percentage of gas (25 % maximum) is confirmed. Leak detection fluids are also suitable for use with most refrigerants but the use of detergents containing chlorine shall be avoided as the chlorine may react with the refrigerant and corrode the copper pipework.

**NOTE** Examples of leak detection fluids are:

- bubble method,
- fluorescent method agents.

If a leak is suspected, all naked flames shall be removed/extinguished. If a leakage of refrigerant is found which requires brazing, all of the refrigerant shall be recovered from the system, or isolated (by means of shut off valves) in a part of the system remote from the leak.

## 5. REMOVAL / EVACUATION OF REFRIGERANT

When breaking into the refrigerant circuit to make repairs - or for any other purpose - conventional procedures shall be used. However, for flammable refrigerants it is important that best practice be followed, since flammability is a consideration. The following procedure shall be adhered to:

- a) safely remove refrigerant following local and national regulations.
- b) purge the circuit with inert gas.
- c) evacuate (optional for A2L).
- d) purge with inert gas (optional for A2L).
- e) open the circuit by cutting or brazing.
- f) The refrigerant charge shall be recovered into the correct recovery cylinders if venting is not allowed by local and national codes. For appliances containing flammable refrigerants, the system shall be purged with oxygen-free nitrogen to render the appliance safe for flammable refrigerants. This process might need to be repeated several times. Compressed air or oxygen shall not be used for purging refrigerant systems. For appliances containing flammable refrigerants, refrigerants purging shall be achieved by breaking the vacuum in the system with oxygen-free nitrogen and continuing to fill until the working pressure is achieved, then venting to atmosphere, and finally pulling down to a vacuum (optional for A2L). This process shall be repeated until no refrigerant is within the system (optional for A2L). When the final oxygen-free nitrogen charge is used, the system shall be vented down to atmospheric pressure to enable work to take place. Ensure that the outlet for the vacuum pump is not close to any potential ignition sources and that ventilation is available.

## 6. CHARGING PROCEDURE

In addition to conventional charging procedures, the following requirements shall be followed:

- Ensure that contamination of different refrigerants does not occur when using charging equipment. Hoses or lines shall be as short as possible to minimize the amount of refrigerant contained in them.
- Cylinders shall be kept in an appropriate position according to the instructions.
- Ensure that the REFRIGERATING SYSTEM is earthed prior to charging the system with refrigerant.
- Label the system when charging is complete (if not already).
- Extreme care shall be taken not to overfill the REFRIGERATING SYSTEM.

Prior to recharging the system, it shall be pressure-tested with the appropriate purging gas. The system shall be leak-tested on completion of charging but prior to commissioning. A follow up leak test shall be carried out prior to leaving the site.

## 7. DECOMMISSIONING / RECOVERY

Before carrying out this procedure, it is essential that the technician is completely familiar with the equipment and all its details. It is recommended good practice that all refrigerants are recovered safely. Prior to the task being carried out, an oil and refrigerant sample shall be taken in case analysis is required prior to re-use of recovered refrigerant. It is essential that electrical power is available before the task commences.

- a) Become familiar with the equipment and its operation.
- b) Isolate the system electrically.
- c) Before attempting the procedure, ensure that:
  - Mechanical handling equipment is available, if required, for handling refrigerant cylinders.
  - All personal protective equipment is available and being used correctly.
  - The recovery process is always supervised by a competent person.
  - recovery equipment and cylinders conform to the appropriate standards.
- d) Pump down the refrigerant system, if possible.
- e) If a vacuum is not possible, make a manifold so that refrigerant can be removed from various parts of the system.
- f) Make sure that cylinder is situated on the scales before recovery takes place.
- g) Start the recovery machine and operate in accordance with instructions.
- h) Do not overfill cylinders (no more than 80 % volume liquid charge).
- i) Do not exceed the maximum working pressure of the cylinder, even temporarily.
- j) When the cylinders have been filled correctly and the process completed, make sure that the cylinders and the equipment are removed from site promptly and all isolation valves on the equipment are closed off.
- k) Recovered refrigerant shall not be charged into another REFRIGERATING SYSTEM unless it has been cleaned and checked.

When removing refrigerant from a system, either for servicing or decommissioning, it is recommended good practice that all refrigerants are removed safely. When transferring refrigerant into cylinders, ensure that only appropriate refrigerant recovery cylinders are employed. Ensure that the correct number of cylinders for holding the total system charge is available. All cylinders to be used are designated for the recovered refrigerant and labelled for that refrigerant (i.e. special cylinders for the recovery of refrigerant). Cylinders shall be complete with pressure-relief valve and associated shut-off valves in good working order. Empty recovery cylinders are evacuated and, if possible, cooled before recovery occurs. The recovery equipment shall be in good working order with a set of instructions concerning the equipment that is at hand and shall be suitable for the recovery of all appropriate refrigerants including, when applicable, FLAMMABLE REFRIGERANTS. In addition, a set of calibrated weighing scales shall be available and in good working order. Hoses shall be complete with leak-free disconnect couplings and in good condition. Before using the recovery machine, check that it is in satisfactory working order, has been properly maintained and that any associated electrical components are sealed to prevent ignition in the event of a refrigerant release. Consult manufacturer if in doubt. The recovered refrigerant shall be returned to the refrigerant supplier in the correct recovery cylinder, and the relevant waste transfer note arranged. Do not mix refrigerants in recovery units and especially not in cylinders. If compressors or compressor oils are to be removed, ensure that they have been evacuated to an acceptable level to make certain that FLAMMABLE REFRIGERANT does not remain within the lubricant. The evacuation process shall be carried out prior to returning the compressor to the suppliers. Only electric heating to the compressor body shall be employed to accelerate this process. When oil is drained from a system, it shall be carried out safely.

## 8. LABELLING

Equipment shall be labelled stating that it has been de-commissioned and emptied of refrigerant. The label shall be dated and signed. For appliances containing FLAMMABLE REFRIGERANTS, ensure that there are labels on the equipment stating the equipment contains FLAMMABLE REFRIGERANT.

