

NOTES:

- Handle the case carefully.
- The cardboard stiffener inside the case, and the rear protective panel must remain in place until the chassis is installed to assure case rigidity and squareness.
- If sub-base is to be used, it may be desirable to assemble it to the case before securing the case in the wall.

CASE LOCATION

As a general rule the air conditioner should be located in an outside wall to ensure proper distribution of conditioned air. It should be located in a portion of the wall where there is no electrical wiring or plumbing, and where there are no obstructions immediately inside or outside.

CRITICAL DIMENSIONS

Dimensions

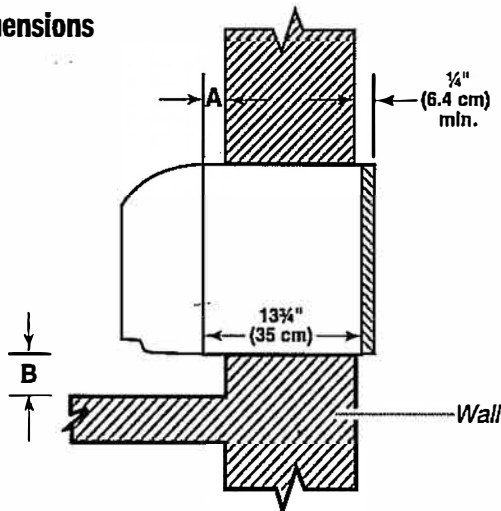

Dimension*	A	B	
	Allow for wall nishing (Minimum)	Allow for door nishing Min.	Max
No Accessories	1/4" (6.4 mm)*	1/4" (6.4 mm)	—
With Subbase	1 3/4" (4.5 cm)	3 1/2" (8.9 cm)	5" (12.7 cm)
With Lateral Duct	3/4" (1.9 cm)	1/4" (6.4 mm)	—

* If more than one accessory is to be used, use the maximum dimension. If the wall thickness is more than 13 3/4" (35 cm) - (A + 1/4" [6.4 mm]), a sleeve extension must be used.

NOTE:

Care should be taken in location of electrical supply entry in relationship to wall sleeve to ensure access to power once the unit is installed.

INSTALL CASE LEVEL IN ALL DIRECTIONS

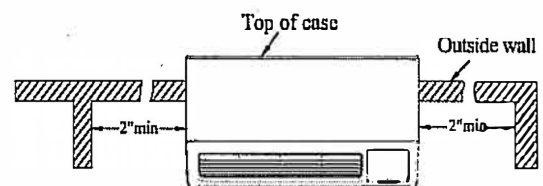

STEP 1

Preparation of the wall

The wall case should be installed during construction and lintels should be used to support the block above the wall case. The case will not support the concrete block or brick. The case is modular in height and width:

Height - Fits 2 courses concrete block

- Fits 5 courses jumbo brick

- Fits 6 courses standard brick

Width - Fits approximately 3 stud spaces.

For existing construction, wall openings must be made. Wall openings of the proper dimensions are essential to avoid the necessity of fillers or additional

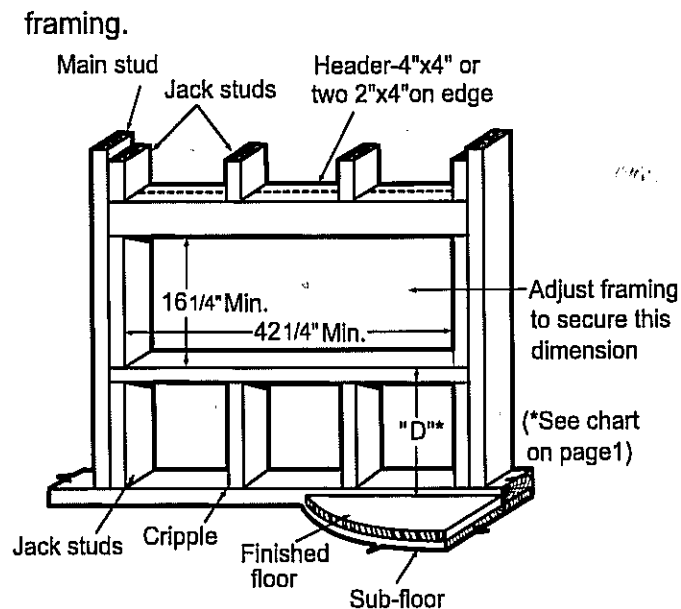

NOTE:

Use lintel to support brick, etc, above the air conditioner case. (if directly under a window sill, the use of a lintel may not be necessary.)

MINIMUM FINISHED OPENING DIMENSIONS*		CASE DIMENSIONS		
Height	Width	Height	Width	Depth
16 1/4"	42 1/4"	16"	42"	13 3/4"

* Dimensions may need to be increased to fit unique situations in the field if using case angles.

STEP 2

Assemble the case

If field-supplied case angles are to be used and must be installed, proceed as follows:

1. Position the case angles around top and sides of the case at the desired location (front to rear) with angles facing toward rear (outside). Position the case angles vertically on each side of the case to provide a level installation.
2. Mark the case through the holes in the case angles.
3. Drill 5/32" diameter holes at marked locations on the case and assemble the angles using only 10x1/2" screws, install the screws from the outside of the case.

NOTE:

Do not drill any holes in bottom of the case

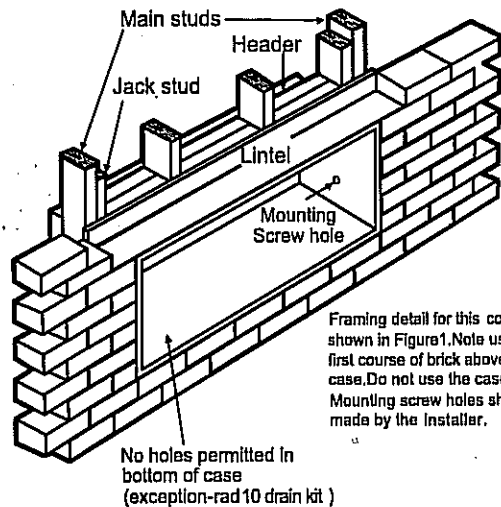

Assemble the case

Step one :Prepare the installation tooling and put the base plate level.

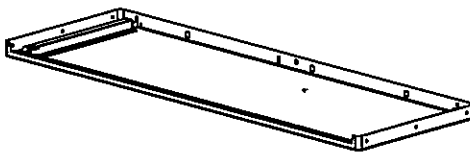

Step two :Mount the two pieces side plate on the base plate.

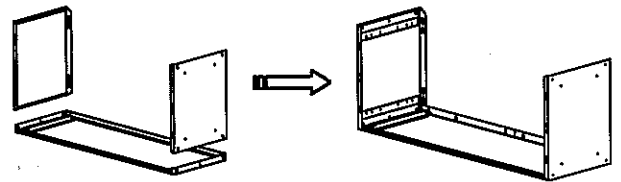

Step three: Mount the top plate.

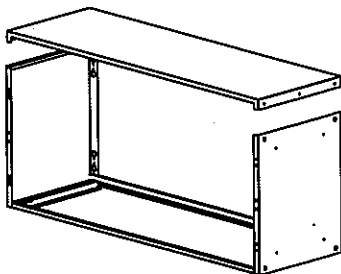

Step four: Screw the 8 screws on the two sides.

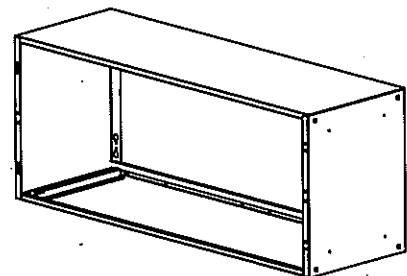

STEP 3

Installation of the case in the wall opening

1. Position the case into the wall. Refer to chart on page 1 for roomside projection. The rear (outside) edge of the case should extend at least 1/4" beyond the outside wall to be able to caulk properly and prevent sealing the drain holes in the rear flange of the case, and to facilitate easy installation of an accessory drain, if desired. (if it is desired to have the rear grille flush on the outside, a drip rail must be installed under the case and caulking applied between the drip rail and case.)

IMPORTANT:

Install case level from side to side and with a slight tilt from front to rear. Use a level; no more than a 1/4 bubble will be the correct case slant to the outside.

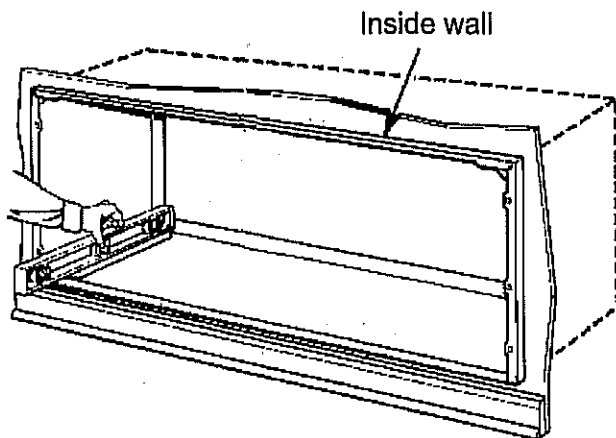

2. Firmly secure the case to the wall structure. Do not drill any holes in the bottom of the case.

Secure case through side and/or top only

2" min. from case bottom

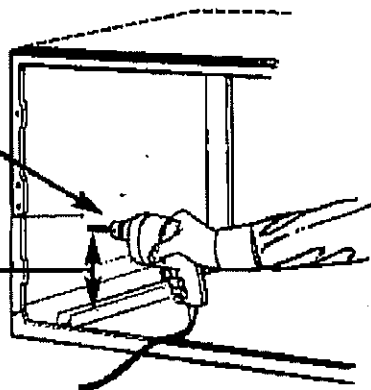

3. Caulk the entire opening on the outside between the case and the building exterior.
 4. Caulk the entire opening on the inside between the case and the building interior.
- Use lintel, when required, to support brick and block above the case.

NOTE:

Do not drill any holes in the case for electrical connections. See the Zoneline Air Conditioner Owner's Manual for instructions on how to connect the electrical supply.

STEP 4

Weatherproofing

Weatherproof gaps between the exterior and interior walls and the case with caulking or equivalent weatherproofing material.

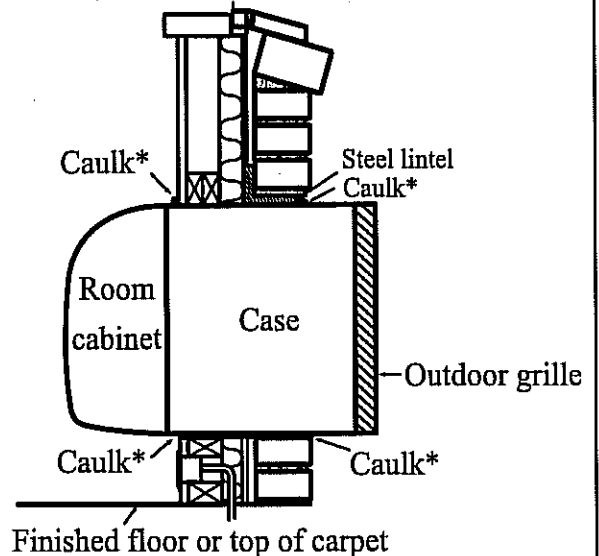

NOTE:

*It is critical to caulk around perimeter of wall case on all four sides where it joins the building to prevent air and water infiltration.

For installation in extra thick walls

1. If the case is being installed in a thick wall where the case is recessed more than 3", an extended wall case will be required with depths as called out in the table in Step 1.
2. If the case is being installed in a wall where the recess is 3" or less, and an extended wall case is not used, flashing must be installed under the case and extend up 2" on each side. The flashing must include a drip rail as illustrated in the figure below.

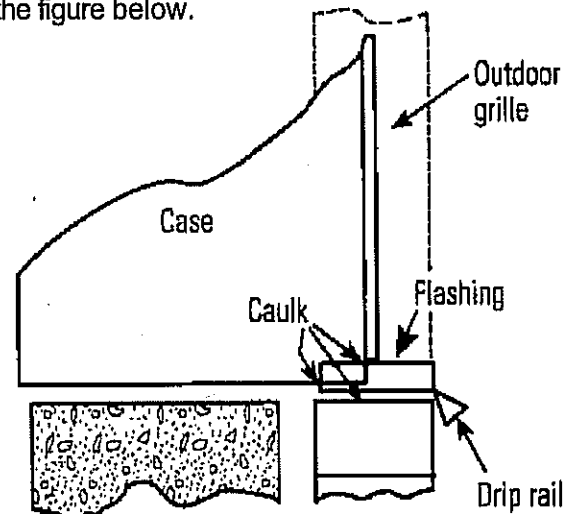

NOTE:

*It is critical to caulk around perimeter of wall case on all four sides where it joins the building to prevent air and water infiltration.

ELECTRICAL REQUIREMENTS(230V/208V)

Provisions should be made to have the proper electrical outlet near the case. All wiring should be made in accordance with local codes and regulations. The line cord included with the chassis (if used) will extend to a wall receptacle located within the area shown in tabulation below.

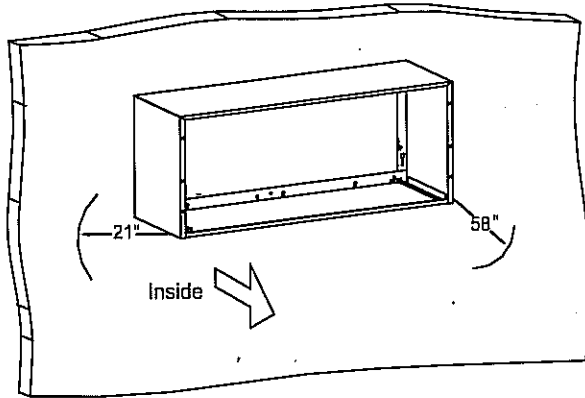

Wall Receptacles

230V/208V 15 amp	230V/208V 20 amp	230V 30 amp
"tandem" type	"perpendicular" type	"tandem" type

All wiring should be made in accordance with local electrical codes and regulations. See the Owner's Manual for how to connect electrical supply.

NOTE:

Aluminum wiring in structure may pose special problems-consult a qualified electrician.

ELECTRICAL REQUIREMENT (265V)

! WARNING:

Connection of a 265V product to a branch circuit must be done by direct connection to be in compliance with the National Electric Code plugging a 265V unit directly into a building-mounted exposed receptacle is not permitted by code.

See the Owner's Manual for how to connect the electrical supply.

DRAIN KIT

If it is necessary to install a drain kit on this wall case, the following kit is available:

RAD10 Internal/External Drain

1. With an "External Drain "(which may be connected to a field -supplied drain line), condensate water can be drained away from the unit and building.

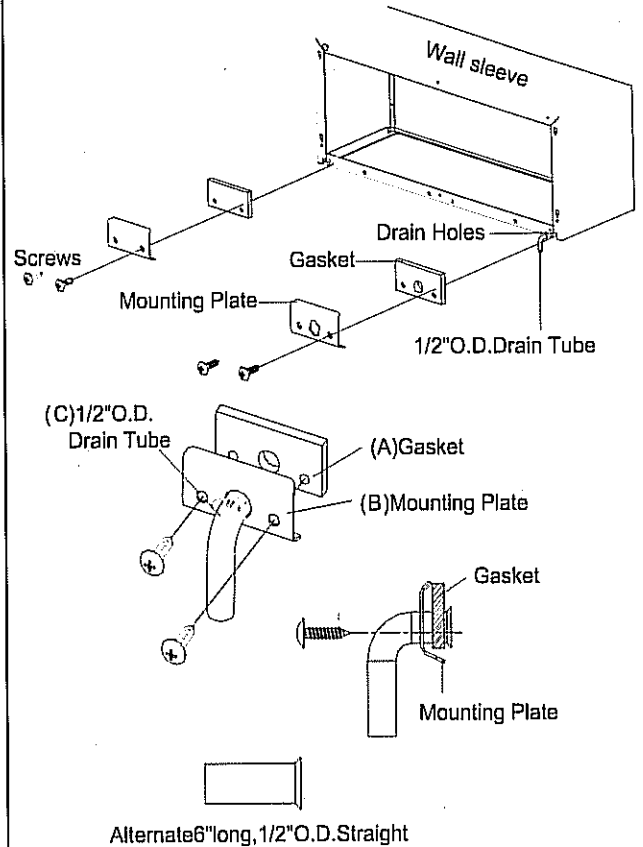

NOTE:

It may be desirable or necessary to install the drain kit on the case prior to installing the case into the wall.

