

INSTALLATION INSTRUCTIONS:

- 1: REMOVE 4 SCREWS HOLDING FRONT COVER TO THE SKIRTBASE
- 2: WIRE RECEPTACLE AND ATTACH TO RECEPTACLE BOX (FOLLOWING ALL REVELANT WIRING CODES FOR YOUR AREA)
- 3: REMOVE FRONT SLEEVE SCREW FROM SLEEVE
- 4: ATTACH SKIRT BASE TO SLEEVE USING SCREW REMOVED FROM THE SLEEVE
- 5: ADJUST EXTENSION PIECES TO WALL IF NEEDED CUT TABS AT SLOT AND BRAKE OFF EXTENSION TO DESIRED LENGTH
- 6: USING THE SELF TAPPING SCREWS PROVIDED ATTACH EXTENSIONS TO SKIRT BASE
- 7: ATTACH FRONT COVER USING THE 4 SCREWS REMOVED IN STEP ONE.

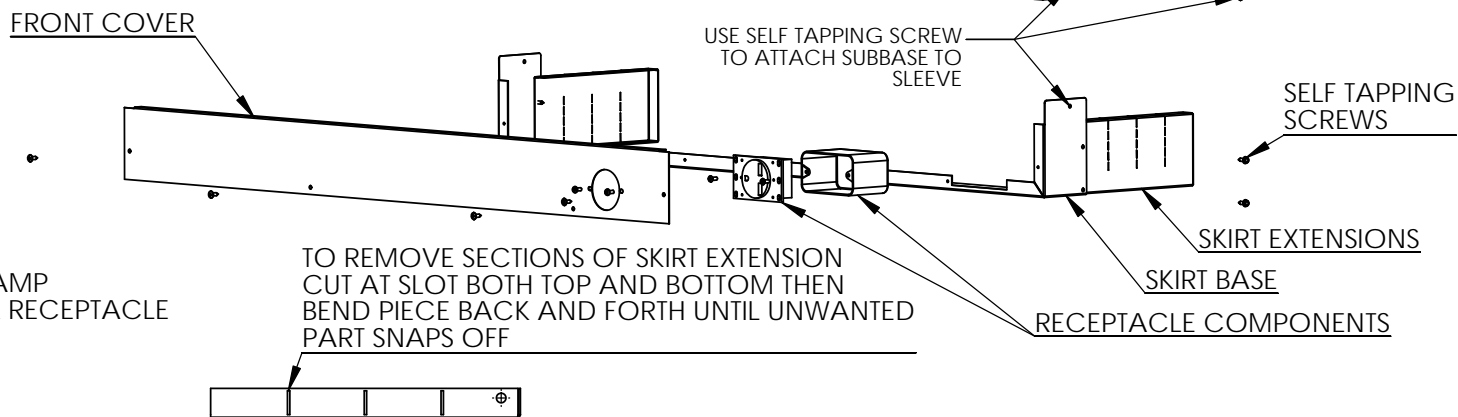
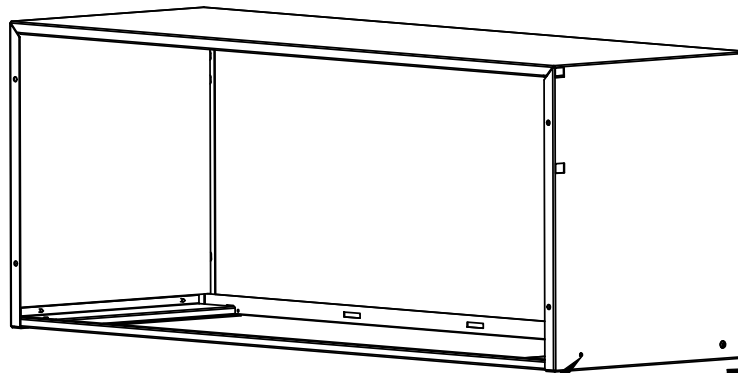
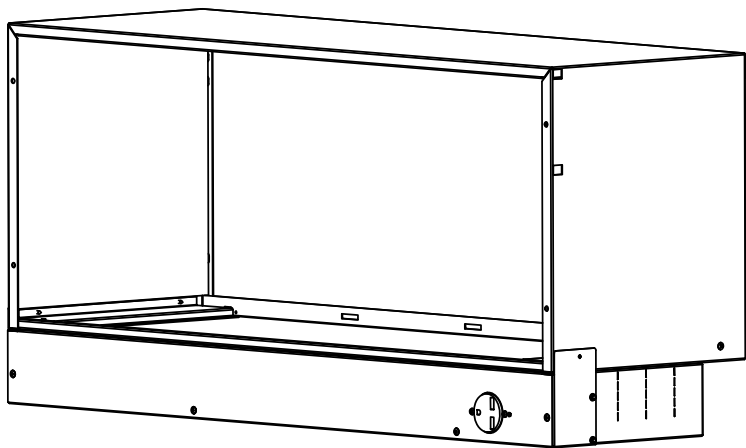

NOTE:
WITH 30AMP RECEPTACLE GROUND LUG MUST BE TO THE LEFT SIDE

WITH 20 AMP RECEPTACLE GROUND LUG MUST BE TO THE RIGHT SIDE. 20 AMP RECEPTACLE REQUIRES THE USE OF A RECEPTACLE FACE PLATE

SEE SHEET 2 FOR 277V UNITS



				NAME	DATE
				DRAWN WWebber	14 May 2014
				CHECKED	
				ENG APPR	
				MFG APPR	
				Q.A.	
				MATERIAL	COMMENTS:
				FINISH	
01	05Jan15	ADDED SHEET 2 FOR 277V UNITS	WW		
REV	DATE	NOTES	BY		
APPLICATION			DC	NOT SCALE DRAWING	

TITLE: INSTALLATION INSTRUCTIONS		
SIZE G	DWG. NO. 803512	REV 01
SCALE: 1:10	WEIGHT:	SHEET 1 OF 2

PROPRIETARY AND CONFIDENTIAL
THE INFORMATION CONTAINED IN THIS DRAWING IS THE SOLE PROPERTY OF <INSERT COMPANY NAME HERE>. ANY REPRODUCTION IN PART OR AS A WHOLE WITHOUT THE WRITTEN PERMISSION OF <INSERT COMPANY NAME HERE> IS PROHIBITED.

277 VOLT UNITS ONLY
 THE CORD COVER PROVIDED MUST BE ATTACHED TO THE UNIT
 THIS COVER IS A CSA REQUIREMENT AND MUST BE IN PLACE
 TO INSURE SAFE OPERATION OF THE UNIT

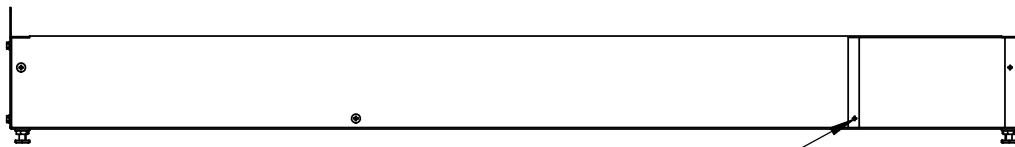

AFTER INSTALLING UNIT AND
 INSERTING CORD REMOVE THE
 2 SCREWS HOLDING THE FRONT
 ALIGN THE CORD COVER WITH
 THE 2 HOLES AND REINSTALL THE SCREWS

COVER FOR
 277V UNITS ONLY

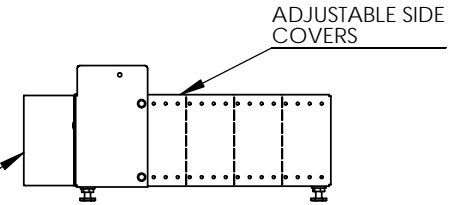

NOTES:

- 1- ATTACH RECEPTACLE TO RECEPTACLE BOX THEN ATTACH TO FRONT COVER USING SCREWS PROVIDED.
- 2- ATTACH FRONT COVER TO BASE (803632) USING 4- 85589 PAN HEAD SCREWS.
- 3- PUT 4- 85132 HEX HEAD SCREWS INTO BAG AND SEAL.
- 4- PLACE BASE ASSEMBLY, BAG CONTAINING SCREWS AND, 2- 803631 EXTENSIONS INTO BOX FOR SHIPPING.

				NAME		DATE		<p style="text-align: center;">Applied COMFORT</p> <p style="text-align: center;">277 VOLT SUBBASE</p>			
				DRAWN		WWebber				05Jan2105	
				CHECKED							
				ENG APPR							
				MFG APPR							
				Q.A.				<p>SIZE G DWG. NO. 803512 REV 01</p> <p>SCALE: 1:10 WEIGHT: SHEET 2 OF 2</p>			
				MATERIAL						COMMENTS:	
REV		DATE		NOTES		BY		FINISH			
APPLICATION				DO NOT SCALE DRAWING							

PROPRIETARY AND CONFIDENTIAL
 THE INFORMATION CONTAINED IN THIS
 DRAWING IS THE SOLE PROPERTY OF
 <INSERT COMPANY NAME HERE>. ANY
 REPRODUCTION IN PART OR AS A WHOLE
 WITHOUT THE WRITTEN PERMISSION OF
 <INSERT COMPANY NAME HERE> IS
 PROHIBITED.