

INSTALLATION INSTRUCTIONS:

- 1: REMOVE 4 SCREWS HOLDING FRONT COVER TO THE SKIRTBASE
- 2: WIRE RECEPTACLE AND ATTACH TO RECEPTACLE BOX (FOLLOWING ALL REVELANT WIRING CODES FOR YOUR AREA)
- 3: REMOVE FRONT SLEEVE SCREW FROM SLEEVE
- 4: ATTACH SKIRT BASE TO SLEEVE USING SCREW REMOVED FROM THE SLEEVE
- 5: ADJUST EXTENSION PIECES TO WALL IF NEEDED CUT TABS AT SLOT AND BRAKE OFF EXTENSION TO DESIRED LENGTH
- 6: USING THE SELF TAPPING SCREWS PROVIDED ATTACH EXTENSIONS TO SKIRT BASE
- 7: ATTACH FRONT COVER USING THE 4 SCREWS REMOVED IN STEP ONE.

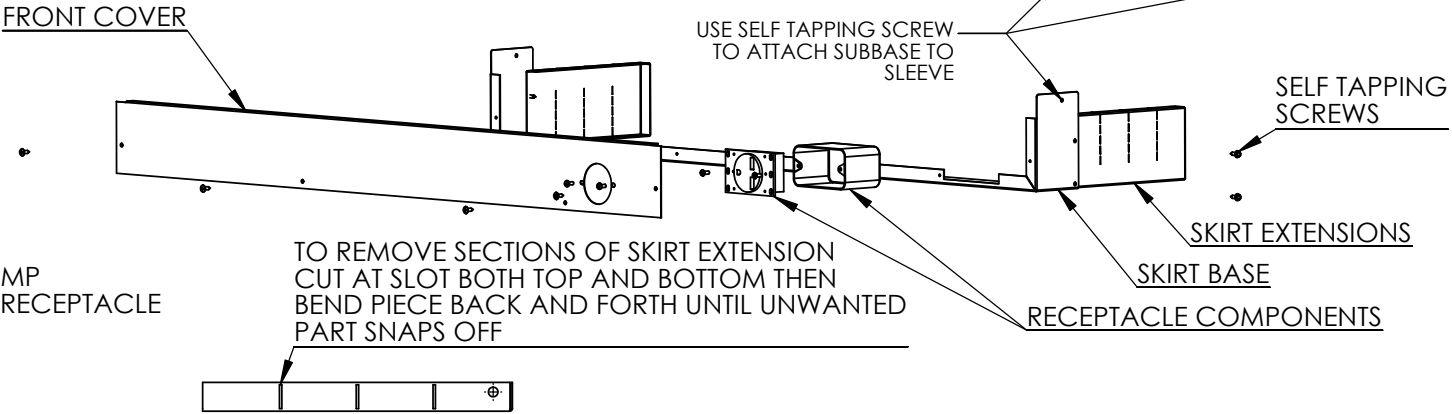
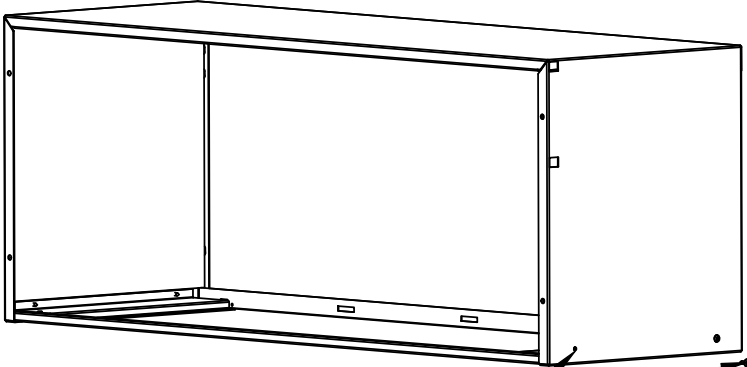
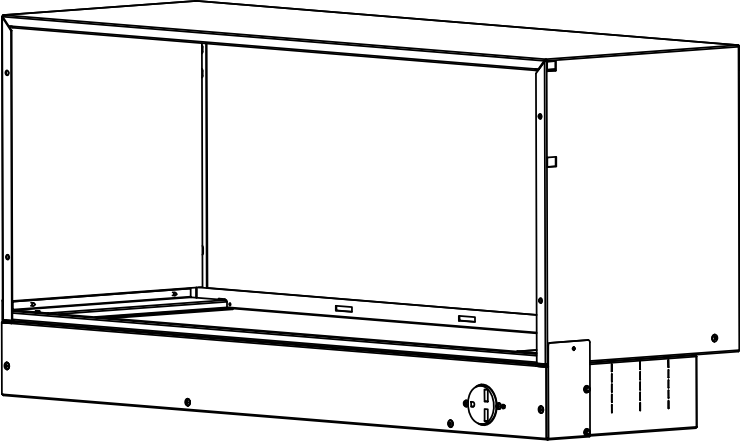

NOTE:
WITH 30AMP RECEPTACLE GROUND LUG MUST BE TO THE LEFT SIDE

WITH 20 AMP RECEPTACLE GROUND LUG MUST BE TO THE RIGHT SIDE. 20 AMP RECEPTACLE REQUIRES THE USE OF A RECEPTACLE FACE PLATE

SEE SHEET 2 FOR 277V UNITS



					NAME	DATE
					DRAWN WWebber	14 May 2014
					CHECKED	
					ENG APPR.	
					MFG APPR.	
					Q.A.	
					MATERIAL	COMMENTS:
					FINISH	
01	05Jan15	ADDED SHEET 2 FOR 277V UNITS	WW			
REV	DATE	NOTES	BY			
		APPLICATION	DC		NOT SCALE DRAWING	

TITLE: INSTALLATION INSTRUCTIONS		
SIZE G	DWG. NO. 803512	REV 01
SCALE: 1:10	WEIGHT:	SHEET 1 OF 2

PROPRIETARY AND CONFIDENTIAL
THE INFORMATION CONTAINED IN THIS DRAWING IS THE SOLE PROPERTY OF <INSERT COMPANY NAME HERE>. ANY REPRODUCTION IN PART OR AS A WHOLE WITHOUT THE WRITTEN PERMISSION OF <INSERT COMPANY NAME HERE> IS PROHIBITED.

277 VOLT UNITS ONLY
 THE CORD COVER PROVIDED MUST BE ATTACHED TO THE UNIT
 THIS COVER IS A CSA REQUIREMENT AND MUST BE IN PLACE
 TO INSURE SAFE OPERATION OF THE UNIT

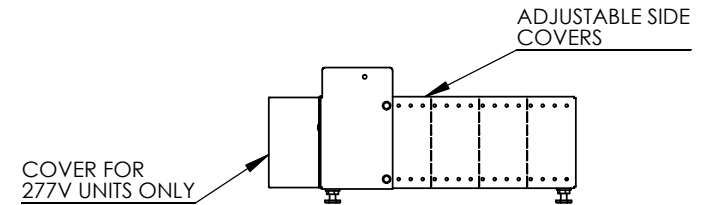
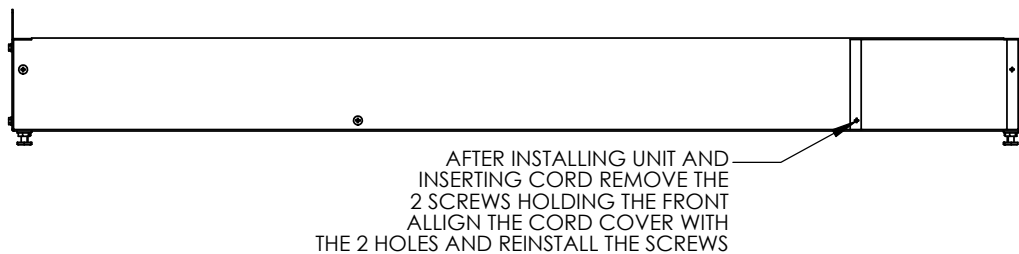

- NOTES:
- 1- ATTACH RECEPTACLE TO RECEPTACLE BOX THEN ATTACH TO FRONT COVER USING SCREWS PROVIDED.
 - 2- ATTACH FRONT COVER TO BASE (803632) USING 4- 85589 PAN HEAD SCREWS.
 - 3- PUT 4- 85132 HEX HEAD SCREWS INTO BAG AND SEAL.
 - 4- PLACE BASE ASSEMBLY, BAG CONTAINING SCREWS AND, 2- 803631 EXTENSIONS INTO BOX FOR SHIPPING.

PROPRIETARY AND CONFIDENTIAL THE INFORMATION CONTAINED IN THIS DRAWING IS THE SOLE PROPERTY OF <INSERT COMPANY NAME HERE>. ANY REPRODUCTION IN PART OR AS A WHOLE WITHOUT THE WRITTEN PERMISSION OF <INSERT COMPANY NAME HERE> IS PROHIBITED.						NAME		DATE		Applied <small>COMFORT</small>			
						DRAWN		WWebber				05Jan2105	
						CHECKED						TITLE: <h1>277 VOLT SUBBASE</h1>	
						ENG APPR.							
						MFG APPR.							
		Q.A.											
		MATERIAL				COMMENTS:		SIZE		DWG. NO.		REV	
REV		DATE		NOTES				BY		G		803512	
		APPLICATION				DO NOT SCALE DRAWING		SCALE: 1:10		WEIGHT:		SHEET 2 OF 2	