

INSTALLATION OPERATION

Applied
Comfort 

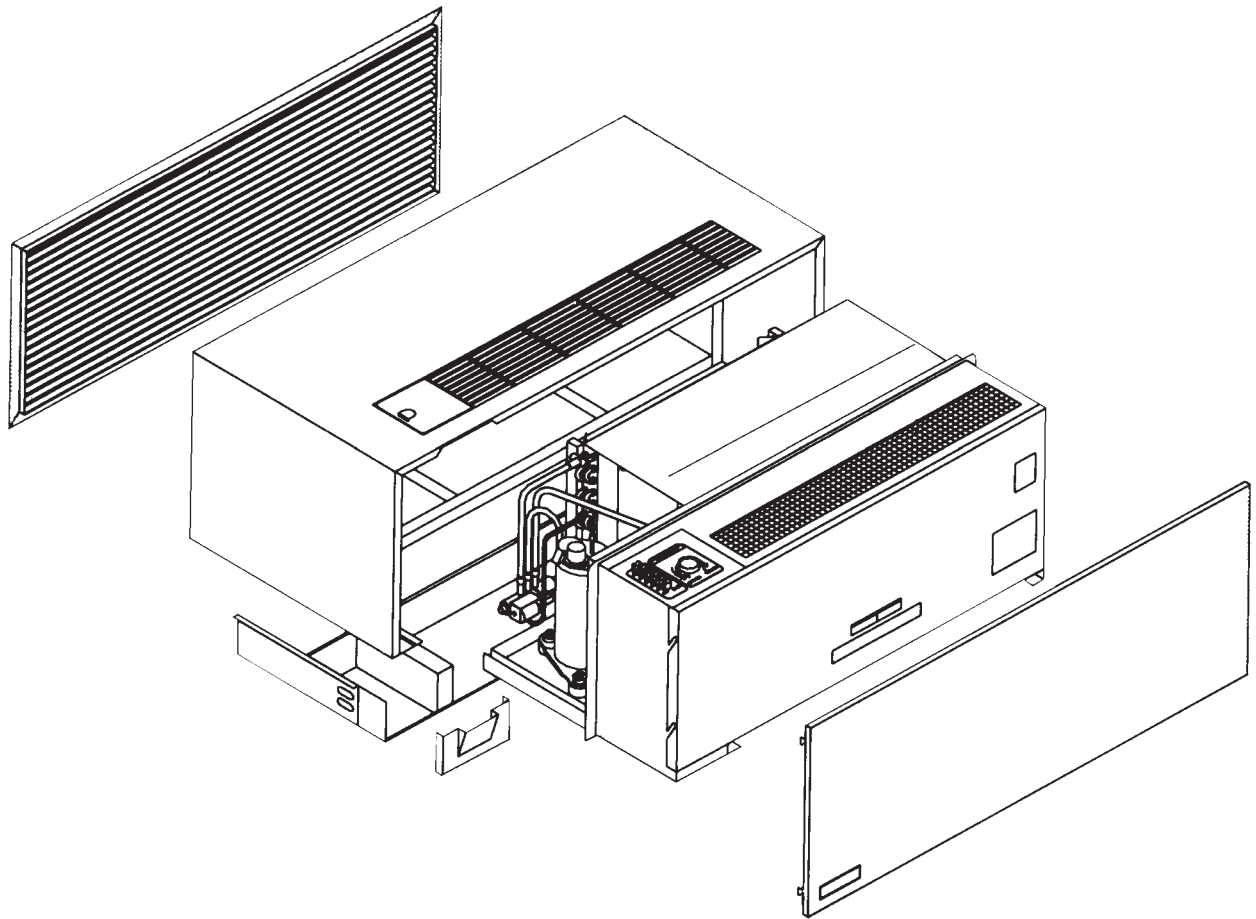

ELECTRIC COOLING/HEATING AND HEAT PUMP PACKAGED TERMINAL AIR CONDITIONERS

1090653 REV. 03 REF ECN06028

General Information

DO NOT INSTALL CHASSIS INTO SLEEVE WITHOUT FIRST READING CHASSIS INSTALLATION PROCEDURE.

RECOMMENDATIONS FOR EFFICIENT OPERATION

- Keep air intake filter clean. Units are provided with a washable filter that can be cleaned with soap and water (we recommend monthly). **IMPROPERLY MAINTAINED FILTER OR NOT USING A FILTER WILL VOID COMPRESSOR WARRANTY.**
- Don't block off the outside air flow to the unit. Paper or other material on the outside of the unit can impair efficiency and cause serious damage to the compressor.
- When unit has been turned OFF, wait three minutes before re-energizing unit.
- In case of power interruption, it is recommended that the unit be turned "OFF" until power has been restored for three minutes. (Operation of the air conditioner with low voltage input can cause serious damage.)
- Clean unit coil and oil motors annually. Some motors are permanently lubricated and do not require annual oiling.

DANGER

To avoid property damage, bodily injury or death, ensure power is disconnected before any service is attempted. Repairs should be made by a qualified air conditioner service technician only.

UNIT OPERATION

(For Units Equipped with Heating Option)

GENERAL

Temperature control is automatic once you have selected desired mode of heat or cool and the temperature you wish to maintain in the room. No further adjustments are necessary for your comfort control.

The heat pump heating cycle will automatically switch from heat pump mode to electric resistance heat when outdoor ambient temperature drops below the design temperature of the unit.

The buttons on the control panel determine the mode (heat or cool) and the thermostat pointer on the control panel determines the room temperature.

THERMOSTAT OPERATION WHEN STARTING:

Set the dial in the mid position to begin operation. After several hours of operation adjust to desired comfort setting. No further adjustment is necessary. Your unit will bring the room back to the desired temperature each time you turn the unit on.

ADJUSTING DURING OPERATION:

Move the dial a small amount at a time in the direction you wish the temperature to go. Moving the dial more than 1/8 inch at a time may overcompensate and lead to an extreme hot or cold situation.

EMERGENCY HEAT OPERATION (Heat Pump Units Only)

In the unlikely event of a compressor failure, the electric heater can be manually energized.

By removing the front panel of sleeve cabinet, you will find a manual emergency heat switch located on the lower left side of the chassis in the excess cable storage area. The switch is marked "**EMERGENCY HEAT**" and "**NORMAL**". By moving the switch to "**EMERGENCY HEAT**" the resistance heat will come on providing the push-button switch is in the "**HEAT**" mode. See Figure 12, page 10.

The temperature is controlled through the thermostat.

Remember to turn switch to "**NORMAL**" when the unit has been repaired.

UNITS WITH LOW TEMPERATURE THERMOSTAT

Some units may be equipped with a low temperature thermostat.

This option energizes the fan and electric heater whenever the room temperature approaches freezing conditions, regardless of the push-button switch setting.

PUSH-BUTTON OPERATION

Depress these buttons for the following effect:

OFF

Entirely stops system as well as closes vent (if open). If you wish to resume cooling or heating, wait at least 3 minutes before re-starting.

COOL

Starts the air conditioning system on cooling. Cooling will not begin if room temperature is below 60°F (16°C).

HEAT

Starts the unit on heating.

A heat pump, unlike an electric or gas furnace, will not supply extremely hot air from the discharge grille.

Depending on the outside temperature the air leaving the grilles will vary. Any air temperature below 102°F (49°C) will feel cool to the human body. This does not mean the system is not working properly.

HIGH

Activates indoor and outdoor motors on high speed independently of "heat" or "cool" mode for maximum effect.

LOW

Activates indoor and outdoor motors on low speed independently of "heat" or "cool" mode for minimum sound level.

VENT ON

Allows outside air to enter the room. The vent door closes automatically when "OFF" button is depressed. Cooling or heating is more efficient when vent is closed. Open vent when fresh air is desired.

VENT OFF

Closes vent door while unit is in operation.

TEMPERATURE LIMITING THERMOSTAT (If Equipped)

Remove the thermostat knob and observe its plastic rib directly under the RED indicator line. Also observe the eight holes in the dial plate surrounding the thermostat stem. Refer to Figure 1 showing letters "A" through "H" identifying these holes for future reference. There should be two screws located in holes "A" and "H". The approximate temperature range (with screws in these positions) is 64° to 89°F (18° to 32°C). Each hole represents approximately 3 1/2° F (2°C) change from adjacent hole.

In Order to set the temperature range, move screws to desired location.

Replace thermostat knob so the RED indicator line is between the two screws.

EXAMPLE: It is desired to limit the temperature range from 71° to 81°F (22° to 27°C). Relocate the two screws in the holes "C" and "F" and replace the thermostat knob so the RED indicator line is between the two screws.

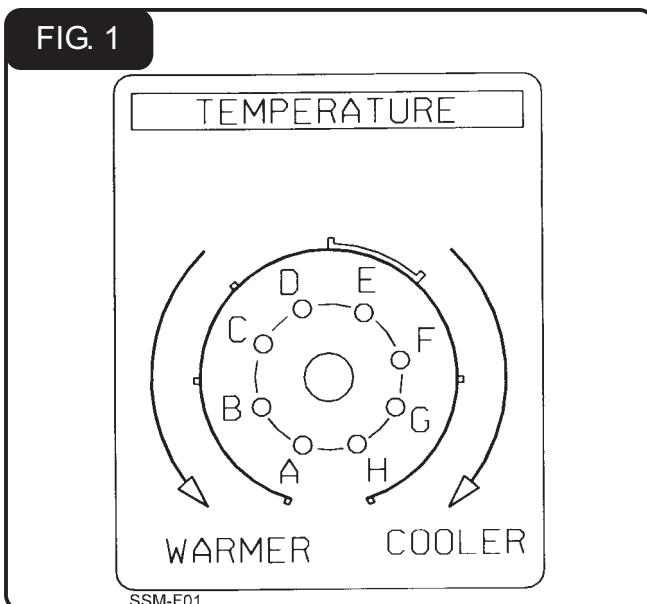

GOOD AIR CONDITIONING PRACTICES

FILTERS

A dirty, clogged filter reduces the efficiency of the system. It can also cause erratic performance of controls and can result in damage to the motor, heating element and compressor.

NOTE

Do not operate the unit with front panel removed, or without filter installed.

Inspect and clean the filter a least once a month or more often as conditions dictate. Replace as necessary. Improperly maintained filter or not using a filter will void warranty.

INDOOR/OUTDOOR COILS

Efficient operation of unit depends on free circulation of air over the indoor and outdoor coils.

DO NOT:

- Stack anything against the indoor or outdoor sections.
- Drape anything against the indoor or outdoor sections.
- Allow furniture, draperies, curtains, etc. to block the free flow of air.
- Plant flowers, vines or shrubbery too near the unit.

DIRTY COILS/BENT FIN

Periodically inspect the indoor and outdoor coils for build-up of lint, dust, leaves, foreign debris, etc., and bent fins.

Clean the coils using a brush and compressed air.

CAUTION

Do not use sharp objects to clean coils or you may puncture the refrigerant tubing.

SNOW AND ICE

In areas of heavy snow and ice accumulation, snow and ice should not be permitted to accumulate against the unit.

As soon as practical after such inclement weather, clear snow and ice from around the unit and as much as possible from the grilles on the unit.

Keep doors and windows closed.

Leaving doors and windows open will increase the workload on the air conditioner or heat pump. This results in higher operating costs.

ELECTRICAL

WARNING

It is the personal responsibility of the customer to retain an electrician who will make sure that all electrical connections and wiring are in conformance with the latest edition of the National Electrical Code and/or Local Codes having jurisdiction.

ELECTRICAL WIRING & NECESSARY WIRE SIZE FOR RECEPTACLE

Use necessary wire size and receptacle to match unit plug and minimum circuit ampacity as stated on the rating plate of the unit.

A single outlet branch circuit from main fuse box to receptacle at unit should be used. Wire size must also take into account any distance from fuse box to receptacle to prevent voltage drops in undersized wires.

Low unit voltage will cause compressor starting problems and decrease the performance and reliability of the compressor.

CAUTION: A subbase kit (Fig. 2) is necessary for permanently connected 208/230 or 277 volt installations.

FIG. 2

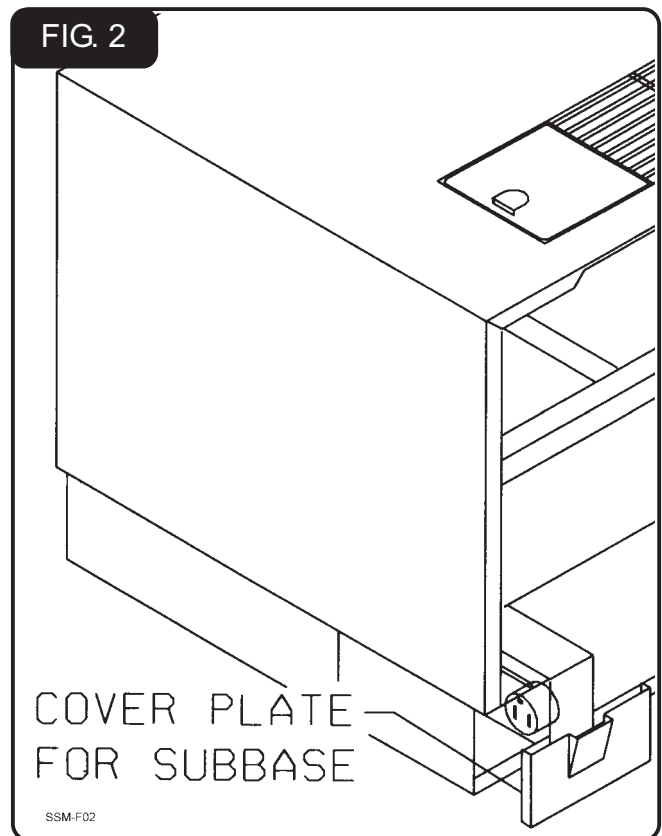

Subbase with electrical receptacle.

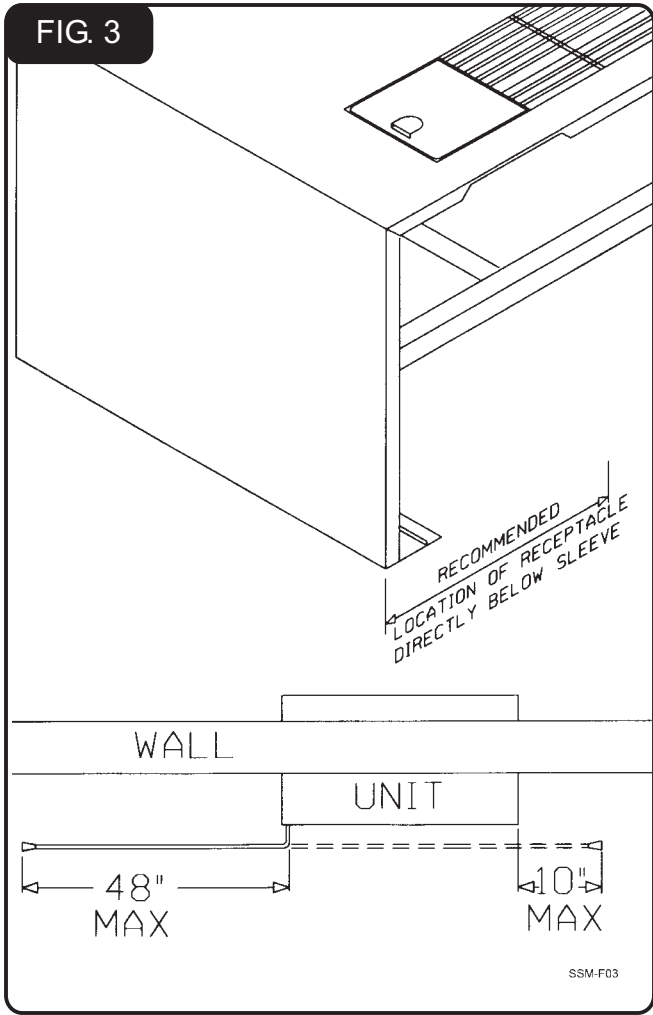

UNITS WITHOUT SUBBASE

For units without a subbase, and to help keep the cord and receptacle out of sight, the electrical receptacle should be located directly below chassis (See Fig. 3).

FUSE/CIRCUIT BREAKER

Use type and size fuse as indicated on the rating plate; or HACR type circuit breaker as indicated on the rating plate of the unit.

SLEEVE CABINET

Sleeve cabinet installation instructions are included with the sleeve in its carton.

FIG. 4

UL SPECIFIED RECEPTACLE CONFIGURATIONS

NAME PLATE RATING		WALL RECEPTACLE NUMBER	RECEPTACLE CONFIGURATION
VOLTS	MAX AMPS		
230/208	UP TO 16	NEMA 5-20R	
230/208	UP TO 24	NEMA 6-30R	

ALL 277 VOLTS UNITS MUST BE PERMANENTLY CONNECTED.
 277 UTILIZE APPROPRIATE SUB-BASE KIT.

SSM-F04

RECEPTACLE

Receptacle must match plug on unit service cord.

DO NOT:

- Change length of service cord.
- Bend /alter or change service cord plug configuration.
- Use extension cords.

WARNING

To avoid property damage, bodily injury or death, the unit must be used on a grounded power supply only.

Unit is grounded through service cord plug and matching receptacle when branch circuit is grounded.

CHASSIS INSTALLATION

CHASSIS FLANGE INSTALLATION (Standard Position)

This position will be used in the majority of sleeves currently installed to date.

The flange is located 8 inches from the front of the chassis.

If unit being replaced is still available, measure distance from the front of chassis to flange, to determine the correct position.

If old unit is not available, install the left side flange as described and continue on with "Chassis Installation", if the chassis will not fit properly, try "Optional Position "A" or "B" described on the following pages.

Unit is shipped from the manufacturer with the top and right chassis flange in place.

Install the left side chassis flange using the following steps:

1. Remove the two screws from the left side of unit where flange would normally be located.
2. Position chassis flange so the flange is facing the front of the unit as illustrated in Figure 5.
3. Using the larger set of holes located closet to the flange end, fasten with screws removed from side of unit in step "1".

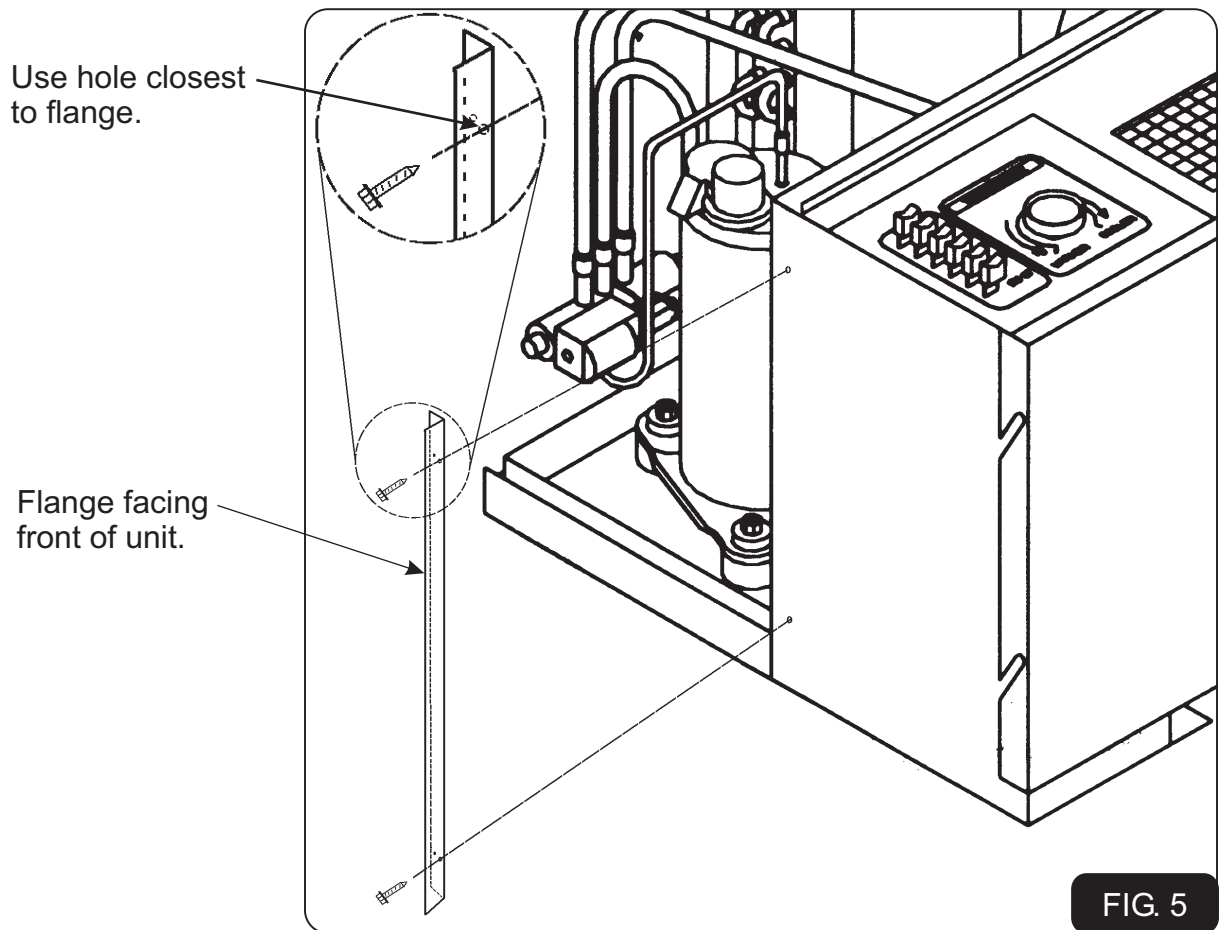

CHASSIS FLANGE INSTALLATION (Optional Position "A")

This position will be used in a small number of sleeves currently installed to date.

The flange is located 8 5/8 inches from the front of the chassis.

If unit being replaced is still available, measure distance from the front of chassis to flange, to determine the correct position.

If old unit is not available, install the left side flange as described and continue on with "Chassis Installation", if the chassis will not fit properly, try "Optional Position "B" described on the following page.

Unit is shipped from the manufacturer with the top and right chassis flange in place.

Install the left side chassis flange using the following steps:

1. Remove the two screws from the left side of unit where flange would normally be located.
2. Position chassis flange so the flange is facing the back of the unit as illustrated in Figure 6.
3. Using the larger set of holes located closet to the flange end, fasten with screws removed from side of unit in step "1".
4. Remove screws holding top and right side chassis flanges, reverse them to match left side flange and reattach them to unit.

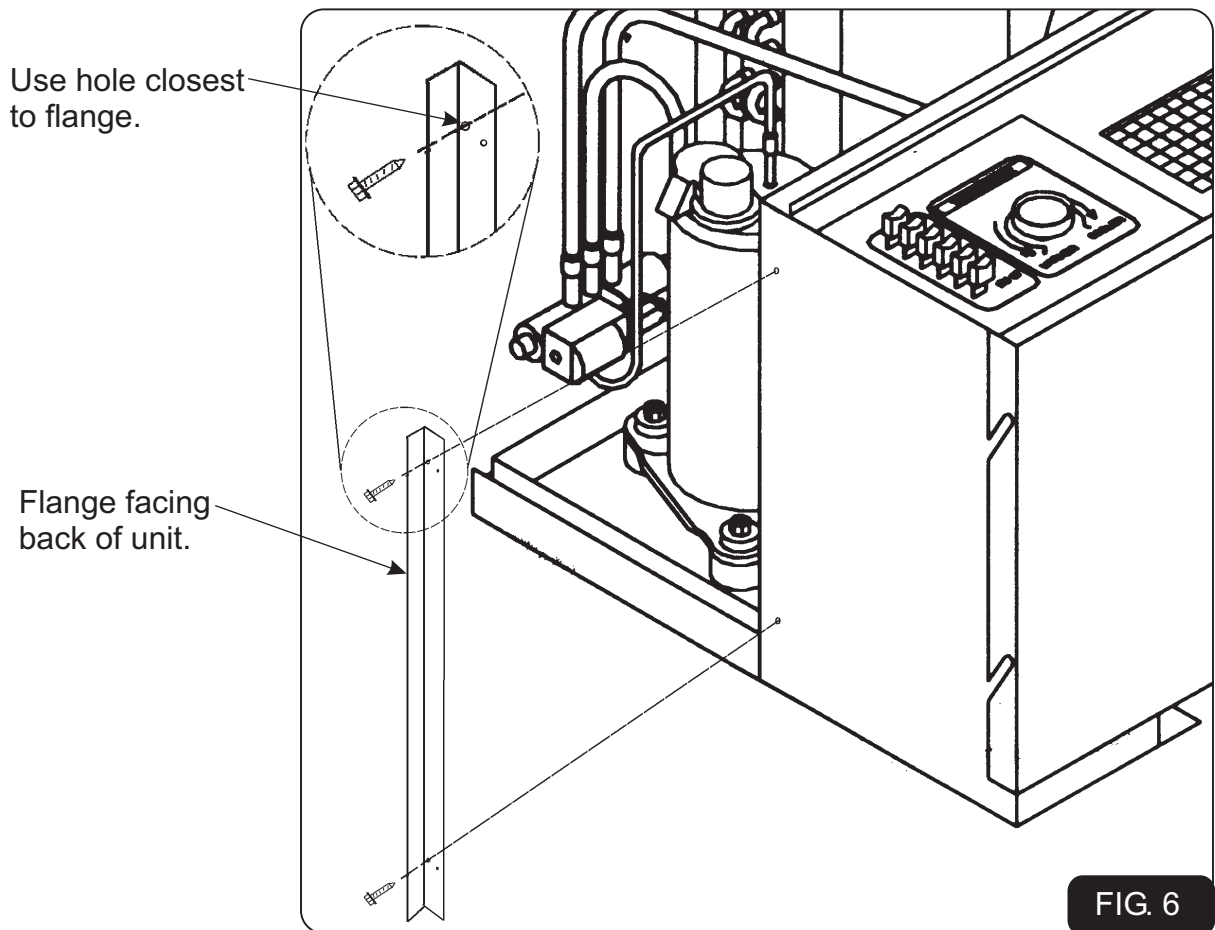

CHASSIS FLANGE INSTALLATION (Optional Position "B")

This position will be used in a small number of sleeves currently installed to date.

The flange is located 9 inches from the front of the chassis.

Unit is shipped from the manufacturer with the top and right chassis flange in place.

Install the left side chassis flange using the following steps:

1. Remove the two screws from the left side of unit where flange would normally be located.
2. Position chassis flange so the flange is facing the back of the unit as illustrated in Figure 7.
3. Using the smaller set of holes located furthest from the flange end, fasten with screws removed from side of unit in step "1".
4. Remove screws holding top and right side chassis flanges, reverse them to match left side flange and reattach them to unit.

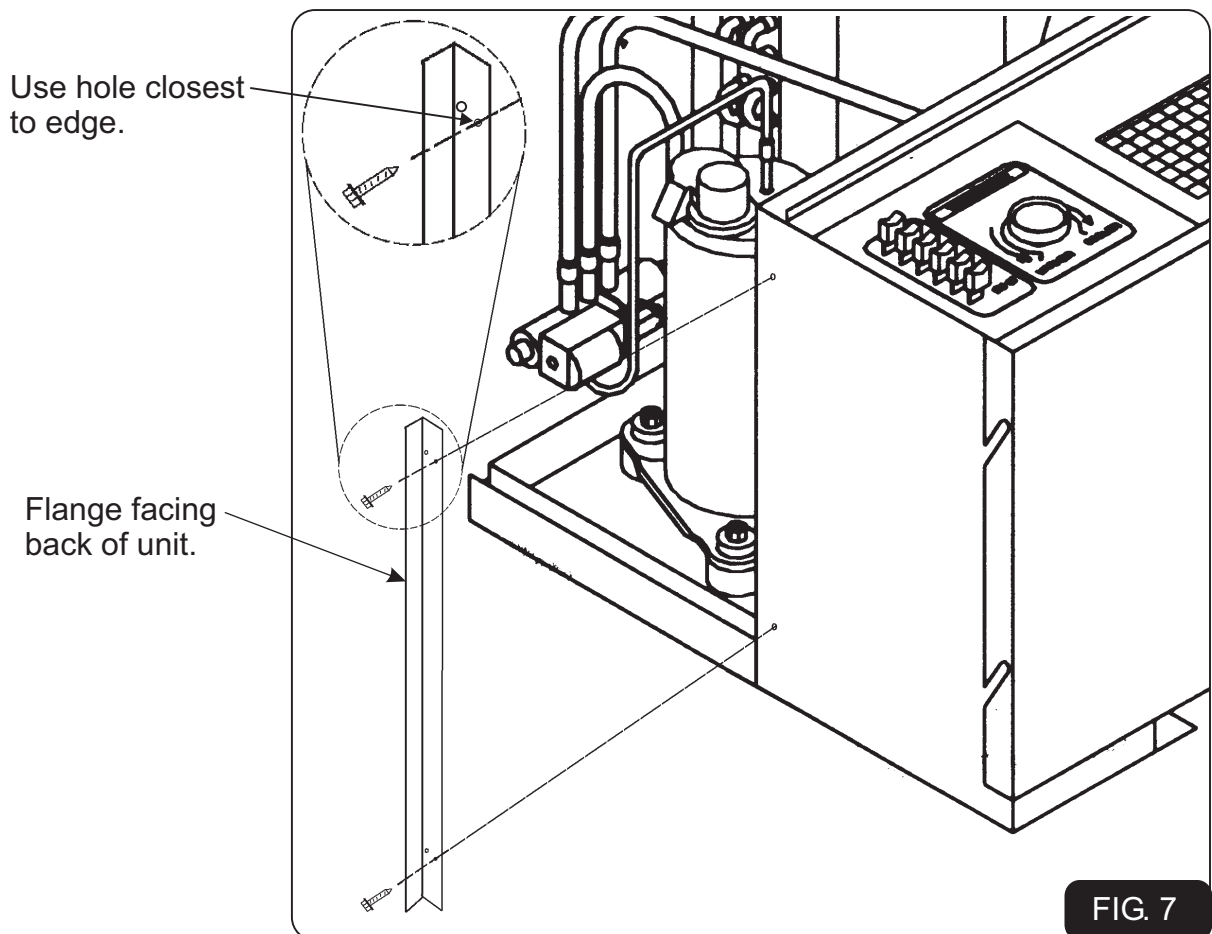

TEMPERATURE CONTROL KNOB

The temperature control knob must be removed before installing chassis into sleeve to gain clearance between sleeve and chassis (See Fig. 8).

INSTALLING CHASSIS

Center chassis in the sleeve and insert into pre-installed sleeve.

CAUTION

Be very careful when installing chassis into sleeve to prevent damage to controls.

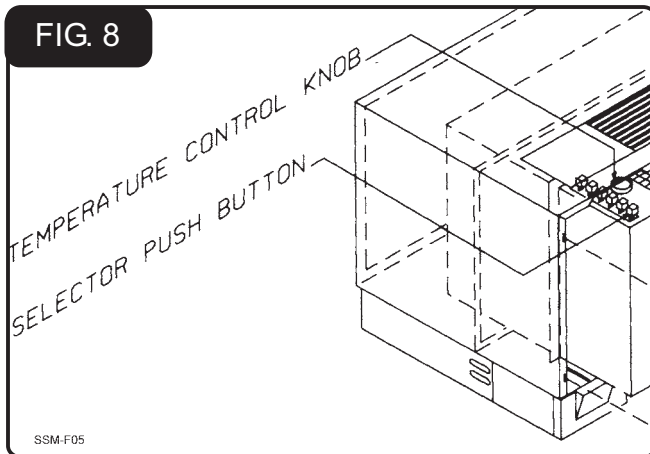

Carefully push chassis into sleeve until chassis flange, (with seal) contacts the flange in the sleeve. (See Fig. 9).

All 3 chassis flanges must be installed in their proper orientation.

Press on the chassis to make sure seal is in good contact with sleeve surface.

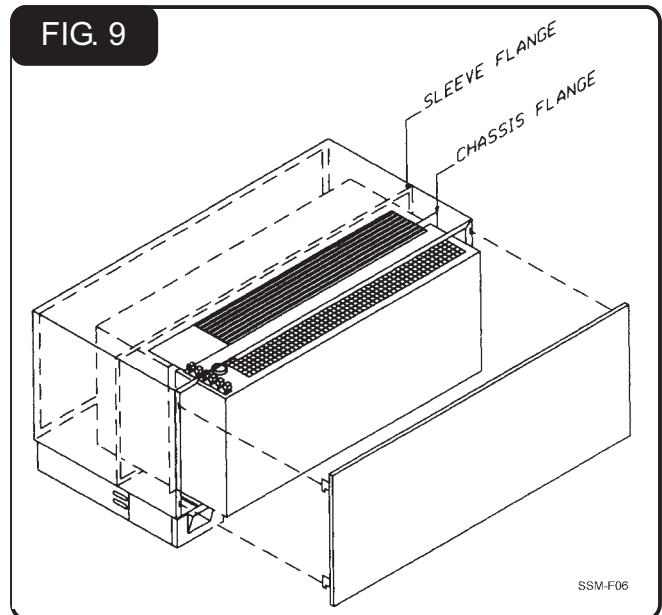

LINE CORD

Plug in line cord to previously installed receptacle, on the wall or within a subbase.

Fold excess line cord into area between sleeve and chassis.

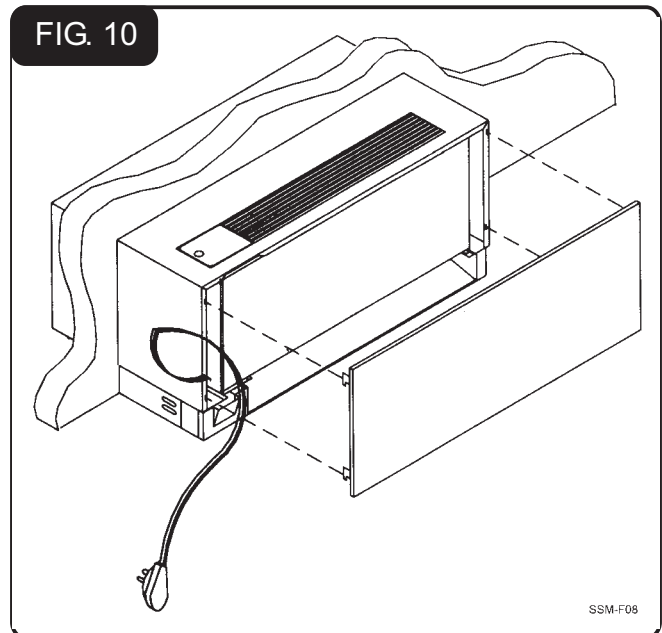

FILTER

A permanent type filter is supplied with unit.

Remove sleeve front panel and install filter horizontally on rails provided.

Replace sleeve front panel (See Fig. 11).

FRONT PANEL

Install front panel making sure locking brackets are inserted into all four slots in sleeve.

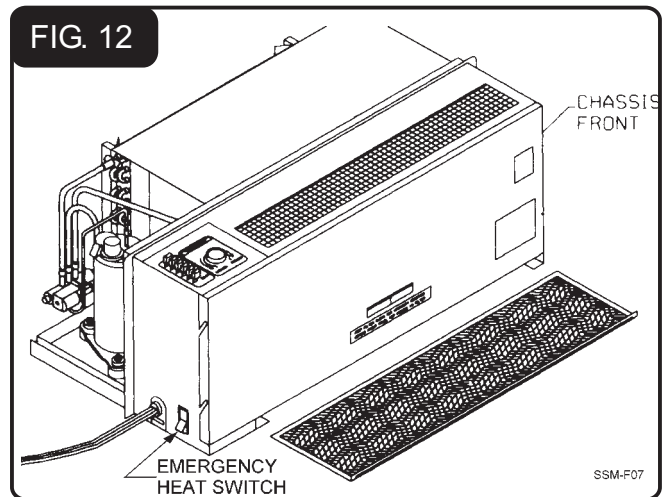
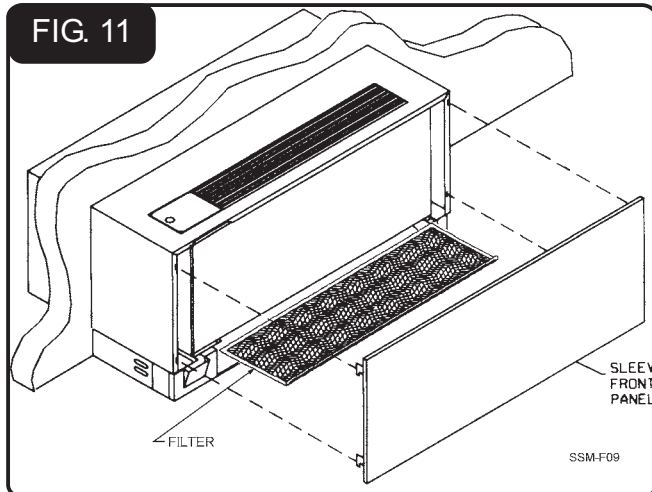

Continuous or Intermittent Fan Operation

Note: Please read these instructions completely before attempting to operate the unit.

When unit is equipped with a continuous/intermittent fan feature, please note the following. The toggle switch is located on the left hand side of the unit and is marked as such. This switch is used to switch between continuous and intermittent fan operation.

With the toggle switch in the “**Continuous**” position, as indicated by the label next to the switch, the indoor fan will continue to operate as long as the unit is switched on in either the heating or cooling mode. The fan will operate continuously at the fan speed selected.

With the toggle switch in the “**Intermittent**” position, and the unit in cooling mode, the indoor fan will operate only when there is a call for cooling by the adjustable thermostat. Similarly with the unit in heating mode, the indoor fan will operate only when there is a call for heating in order to satisfy the heat setting on the adjustable thermostat.

The effective indoor temperature sensing and highest comfort levels are achieved when the room air is being drawn continuously across the sensing bulb of the thermostat.

The most effective indoor temperature sensing and highest comfort levels are achieved when room air is being drawn continuously across the sensing bulb of the unit thermostat. **If complaints of large temperature swings in the room are experienced, then switch the unit to continuous fan operation.**

START-UP CHECKLIST

Note: These units should be installed and checked for proper function by qualified service personnel only.

1. Circuit breakers, wire size, all connections tight and correct
2. Condensate drain adequate (size-pitch-trapped)
3. Filter clean and in place
4. Condenser air inlet and outlet free of obstructions and short circuiting
5. Operate unit 20 minutes
6. Controls operation OK
7. Unit installed in compliance with all codes and ordinances
8. All panels in place
9. Work area clean and free of debris
10. Owner or operator instructed on control operation and routine maintenance
11. Name and phone number of service company attached to unit or noted in telephone directory

TROUBLESHOOTING CHART *

FAULT	CAUSE	CHECK AND CORRECTION
1. Compressor short cycles.	<ul style="list-style-type: none"> a. Low voltage. b. Restricted condenser air. c. Recycling of condenser discharge air into unit. d. Thermostat bulb not properly located. e. Faulty or incorrect overload. 	<ul style="list-style-type: none"> a. Check voltage and amperage with unit running. b. Check condenser motor for continuous run. Check for dirt or other condenser coil restriction. c. Check for inadequate discharge air clearances, baffles missing, coil not sealed against grille, unit not completely into sleeve. d. Check for proper location in return air stream. e. Check overload. If compressor is not overheated, if amperage is not high, change overload.
2. Compressor will not run.	<ul style="list-style-type: none"> a. Defective switch. b. Defective thermostat. c. Broken or loose wiring. d. Running capacitor. e. Overload fault. f. Low voltage. 	<ul style="list-style-type: none"> a. Check voltage into and out of switch thru all phases. Replace if required. b. Replace thermostat. c. Check all connections. d. Check capacitor with tester. e. Check for defective compressor or defective overload. f. Low voltage.
3. Unit blows fuse or trips circuit breaker.	<ul style="list-style-type: none"> a. Shorted or incorrect wiring. b. Shorted capacitor. c. Shorted or stuck compressor. d. Compressor short cycling. e. Compressor hard to start. f. Incorrect fusing. g. Power was interrupted to unit. h. Outdoor temperature too cold. 	<ul style="list-style-type: none"> a. Check all connections. b. Check capacitor with tester. c. Check compressor. d. Check compressor. Check both blower and fan motors for intermittent operation. e. Check for low voltage. Check capacitor. f. Check fuse or circuit breaker size. g. Allow three minutes for Internal Pressure Equalization. h. Compressor not intended to operate in either heating or cooling at cold outdoor temperatures.
4. Unit not cooling properly.	<ul style="list-style-type: none"> a. Dirty air filter. b. Air recirculation inside enclosure. c. Condenser air restricted or recycling of condenser discharge air into unit. d. Low refrigerant or leak. e. Faulty thermostat. 	<ul style="list-style-type: none"> a. Clean or replace. b. Enclosure not sealed to discharge opening on unit. Lower enclosure to seal. c. Check for dirty coil surface. Check for inadequate discharge air clearance, baffles missing, other restrictions causing re-entry of air. d. Check compressor voltage and amperage while running. Check unit for leak. e. Check and replace if defective.
5. Unit rattles or is noisy.	<ul style="list-style-type: none"> a. Refrigerant lines hitting metal parts. b. Loose fan blade. c. Blower motor loose on mounting bracket. d. Loose blower wheel or rubbing housing. 	<ul style="list-style-type: none"> a. Bend tubing slightly to about 3/4" clearances. b. Relocate to clear and tighten. c. Check spring clips. d. Relocate in center of housing and tighten screws. Check when running.
6. Unit will not run.	<ul style="list-style-type: none"> a. Open circuit-blown fuse. b. Broken or loose wiring. c. Low voltage. d. Defective switch. 	<ul style="list-style-type: none"> a. Check voltage at receptacle. Close circuit breaker. Replace fuse. b. Check all connections. c. Check voltage. Check for poor wire connections. d. Check voltage into and out of switch thru all phases. Replace if required.
7. Water drips from unit.	<ul style="list-style-type: none"> a. Sleeve not properly mounted. b. Condensate drain plugged. c. Evaporator pan loose or not properly mounted. d. Condensate drain tube not installed on evaporator pan. e. Internal drain hose leaks. f. Under certain ambient conditions, heat pumps may generate excessive condensate. 	<ul style="list-style-type: none"> a. Check and remount, if possible. b. Clean. c. Reattach mounting clips. d. Reconnect tube to pan. e. Check internal drain hose for source of leak, located directly behind filter. Check seal between drain hose and unit bulkhead in lower right corner. f. If objectionable, connect to internal drain system.

*This Chart Is Provided For Qualified Personnel Only.

SSM-F10