

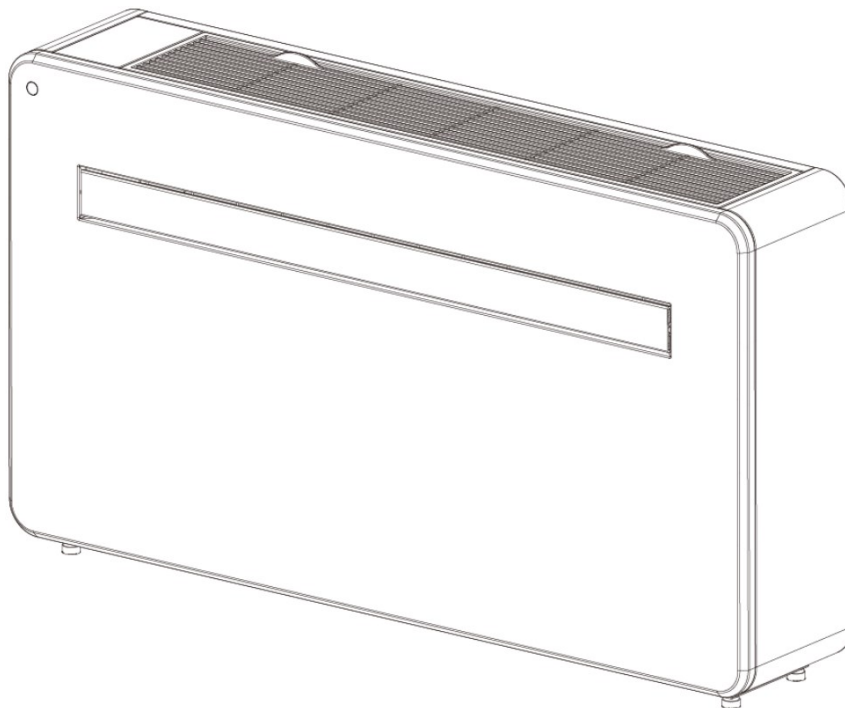

# **COOLFLOW32 USER MANUAL**

TPHE10L00E6A30

115V,60HZ WITHOUT ELECTRIC HEAT



**WALL MOUNTED TWIN PIPE AIR CONDITIONER  
WITH HEAT PUMP AND WIFI SMART APP**

# **CONTENTS**

<b>SAFETY AND INSTRUCTIONS</b>	<b>2</b>
<b>PRODUCT OVERVIEW</b>	<b>7</b>
<b>PRODUCT DIAGRAM</b>	<b>7</b>
<b>FEATURES</b>	<b>8</b>
<b>WHAT'S INCLUDED</b>	<b>8</b>
<b>INSTALLATION</b>	<b>9</b>
<b>TOOLS REQUIRED</b>	<b>10</b>
<b>INSTALLATION</b>	<b>10</b>
<b>OPERATION</b>	<b>15</b>
<b>CONTROL PANEL</b>	<b>15</b>
<b>REMOTE CONTROL</b>	<b>15</b>
<b>FUNCTIONS</b>	<b>17</b>
<b>WIFI SETUP AND SMART FEATURES</b>	<b>18</b>
<b>SETUP</b>	<b>18</b>
<b>REGISTER THE APP</b>	<b>19</b>
<b>CONNECTING USING BLUETOOTH &amp; WIFI</b>	<b>20</b>
<b>TROUBLESHOOTING</b>	<b>23</b>
<b>ERROR CODES</b>	<b>24</b>
<b>MAINTENANCE</b>	<b>25</b>
<b>DISPOSAL</b>	<b>25</b>

## Safety and Instructions

### READ ALL INSTRUCTIONS BEFORE USE.

**Your safety and the safety of others is very important.**

We have provided many important safety messages in this manual and on your appliance. Always read and follow all safety messages.



This symbol shows that this appliance uses a flammable refrigerant. If the refrigerant is leaked and exposed to an external ignition source, there is a risk of fire.



This symbol shows that the operation manual should be read carefully.



This symbol shows that a service personnel should be handling this equipment with reference to the installation manual.



This symbol shows that information is available such as the operating manual or installation manual.



### **WARNING**

You may be killed or seriously injured if you do not follow instructions.



### **CAUTION**

You may be injured or cause damage to the product if you do not follow instructions.

### **Fuse Parameter for the main control board**

**Voltage: AC 250V**

**Current: 15 A**



**To reduce the risk of explosion, fire, death, electric shock, scalding or injury to persons when using this product, follow basic precautions, including the following:**

## **INSTALLATION**

- Before use, the appliance must be properly installed as described in this manual.
- Contact the authorized service technician for repair or maintenance of this unit.
- Contact the installer for installation of this unit.
- When the power cord is to be replaced, replacement work shall be performed by authorized personnel only using only genuine replacement parts.
- Installation work must be performed in accordance with the National Electric Code by qualified and authorized personnel only.
- Connect to a properly rated, protected, and sized power circuit to avoid electrical overload. Always plug into a grounded outlet.
- Do not under any circumstances, cut or remove the third (ground) prong from the power cord.
- When installing or moving the appliance, be careful not to pinch, crush, or damage the power cord.
- Plug in the power plug properly.
- Do not modify or extend the power cord.
- Do not start/stop operation by plugging/unplugging the power cord.
- If the cord/plug is damaged, have it replaced by an authorized service person using authorized replacement parts.
- Use a dedicated circuit.
- Do not disassemble or modify the product.
- Adhere to all industry recommended safety procedures including the use of long-sleeved gloves and safety glasses.
- Use care when unpacking and installing. The edges of the product may be sharp.
- Disconnect the power cord or circuit breaker before installing or servicing the appliance.
- Keep packaging materials out of the reach of children. These materials can pose a suffocation risk to children.
- Store and install the product where the unit's casing will not be exposed to temperatures below freezing or exposed to outdoor weather conditions. In other words, do not allow the whole unit to be exposed to outdoor conditions
- Do not store or use gasoline or other flammable vapors and liquids in the vicinity of this or any other appliance.

## **OPERATION**

- Use this appliance only for its intended purpose.
- Never attempt to operate this appliance if it is damaged, malfunctioning, partially disassembled, or has missing or broken parts, including a damaged cord or plug.
- Repair or immediately replace all power cords that have become frayed or otherwise damaged
- Do not use a cord that shows cracks or abrasion damage along its length or at either end.
- Do not run cord under carpets or mats where it could be stepped on and damaged.

- Keep the cord out from under heavy objects like tables or chairs.
- Do not place the power cord near a heat source.
- Do not use an adaptor or plug the product into a shared outlet.
- Do not tamper with controls.
- If you detect a strange sound, a chemical or burning smell, or smoke coming from the appliance, unplug it immediately, and contact dealer.
- Never unplug the appliance by pulling on the power cord. Always grip the plug firmly and pull straight out from the outlet.
- Do not grasp the power cord or touch the appliance controls with wet hands.
- The air conditioner is not intended for use by young children or invalids without supervision.
- Young children should be supervised to ensure that they do not play with the air conditioner.
- If water enters the product, turn off the power at the main circuit, then unplug the product and call for service.
- If the product has been submerged, contact the dealer for instructions before resuming use.
- Unplug the product when unused for long periods.
- Unplug the product before cleaning. In the event of a gas leak (propane gas, etc.) do not operate this or any other appliance. Open a window or door to ventilate the area immediately.
- This appliance is not intended for use by persons (including children) with reduced physical, sensory or mental capabilities, or lack of experience and knowledge, unless they have been given supervision or instruction concerning the use of the appliance by a person responsible for their safety.
- To clean the interior, contact the dealer. Using harsh detergents may cause corrosion or damage to the unit.
- Do not use solvent-based detergent on the product. Doing so can cause corrosion or damage, product failure, electrical shock, or fire.
- Keep outdoor louvers unblocked and unobstructed by any obstacle closer than 36° to the wall face.

## GROUNDING INSTRUCTIONS

- The power cord of this appliance is equipped with a three-prong (grounding) plug. Use this with a standard three-slot (grounding) wall power outlet to minimize the hazard of electric shock. The customer should have the receptacle and circuit checked by a qualified electrician to make sure the receptacle is properly grounded. ***DO NOT CUT OR REMOVE THE THIRD (GROUND) PRONG FROM THE POWER PLUG.***

Situations when the appliance will be disconnected occasionally; Because of potential safety hazards, we strongly discourage the use of an adapter plug. However, if you wish to use an adapter, a TEMPORARY CONNECTION may be made. Use UL-listed adapter, available from most local hardware stores.

The large slot in the adapter must be aligned with the large slot in the receptacle to assure a proper polarity connection.

- Attaching the adapter ground terminal to the wall receptacle cover screw does not ground the appliance unless the cover screw is metal, and not insulated, and the wall receptacle is grounded to make sure the receptacle is properly grounded.
- Disconnect the power cord from the adapter, using one hand on each. Otherwise, the adapter ground terminal might break. Do not use the appliance with a broken adapter plug. Situations when the appliance will be disconnected often; Do not use an adapter plug in these situations. Unplugging the power cord frequently can lead to an eventual breakage of the ground terminal. The wall power outlet should be replaced by a three-slot (grounding) outlet instead.



## REFRIGERANT (FOR R32 ONLY)

---



### CAUTION: FIRE

**READING THE MAUAL CAREFULLY BEFORE USING THE APPLIANCE R32 refrigerant gas complies with international environmental directives. This appliance contains approximately 19.40 Oz refrigerant gas.**



### Warnings

Do not use means to accelerate the defrosting process or to clean, other than those recommended by the manufacturer.

The appliance shall be stored in a room without continuously operating ignition sources (for example: open flames, an operating gas appliance or an operating electric heater)

Do not pierce or burn.

Be aware that refrigerants may not contain an odour.

The instructions should contain the following information:

That piping material, pipe routing, and installation shall include protection from physical damage in operation and service, and be in compliance with Federal and Local Regulations.

All field joints shall be accessible for inspection prior to being covered or enclosed.

- The installation of pipe-work shall be kept to a minimum.
- The provision shall be made for expansion and contraction of long runs of piping;
- The protection devices, piping, and fittings shall be protected as far as possible against adverse environmental effects, for example, the danger of water collecting and freezing in relief pipes or the accumulation of dirt and debris;
- The piping in refrigeration systems shall be so designed and installed to minimize the likelihood of hydraulic shock damaging the system;
- The steel pipes and components shall be protected against corrosion with a rustproof coating before applying any insulation;
- The flexible pipe elements shall be protected against mechanical damage, excessive stress by torsion, or other forces, and that they should be checked for mechanical damage annually;
- The precautions shall be taken to avoid excessive vibration or pulsation.



**When using the product, the room should keep any required ventilation openings clear of obstruction. Notice that servicing shall be performed only as recommended by the manufacturer.**

### **Unventilated area**

- That an unventilated area where the appliance using flammable refrigerants is installed shall be so constructed that should any refrigerant leak, it will not stagnate so as to create a fire or explosion hazard.



- The non-fixed appliance shall be stored in an area where the size corresponds to the room area as specified for operation.



- The non-fixed appliance shall be stored in a room without continuously operating open flames or other potential ignition sources.

- The manufacturer should specify other potential continuously operating sources known to cause ignition of the refrigerant used.

- The appliance shall be stored so as to prevent mechanical damage from occurring.

- Non-duct connected appliances containing A2L refrigerants with the supply and return air openings in the conditioned space may have the body of the appliance may be installed in open areas such as false ceilings not being used as return air plenums, as long as the conditioned air does not directly communicate with the air of the false ceiling.

### **Qualification of workers**

- All operators or refrigeration circuit maintenance personnel should obtain a valid certificate issued by an industry-recognized evaluation agency to determine that they have the qualifications to safely handle refrigerants as required by the industry-recognized evaluation scope.

- Only perform equipment maintenance and repairs in accordance with the methods recommended by the appliance manufacturer. If other professional is required to assist in maintenance and repairs, they should be carried out under the supervision of personnel qualified to use **flammable refrigerants**.

# PRODUCT OVERVIEW

## PRODUCT DIAGRAM

### FRONT

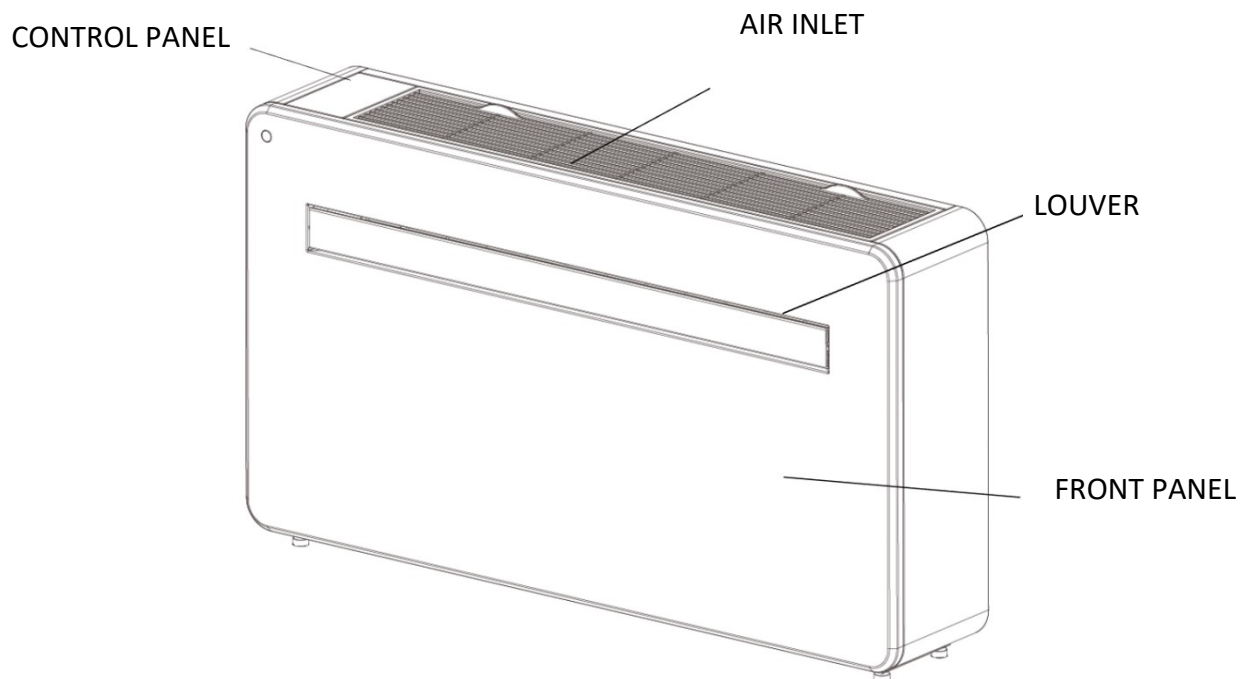

### BACK

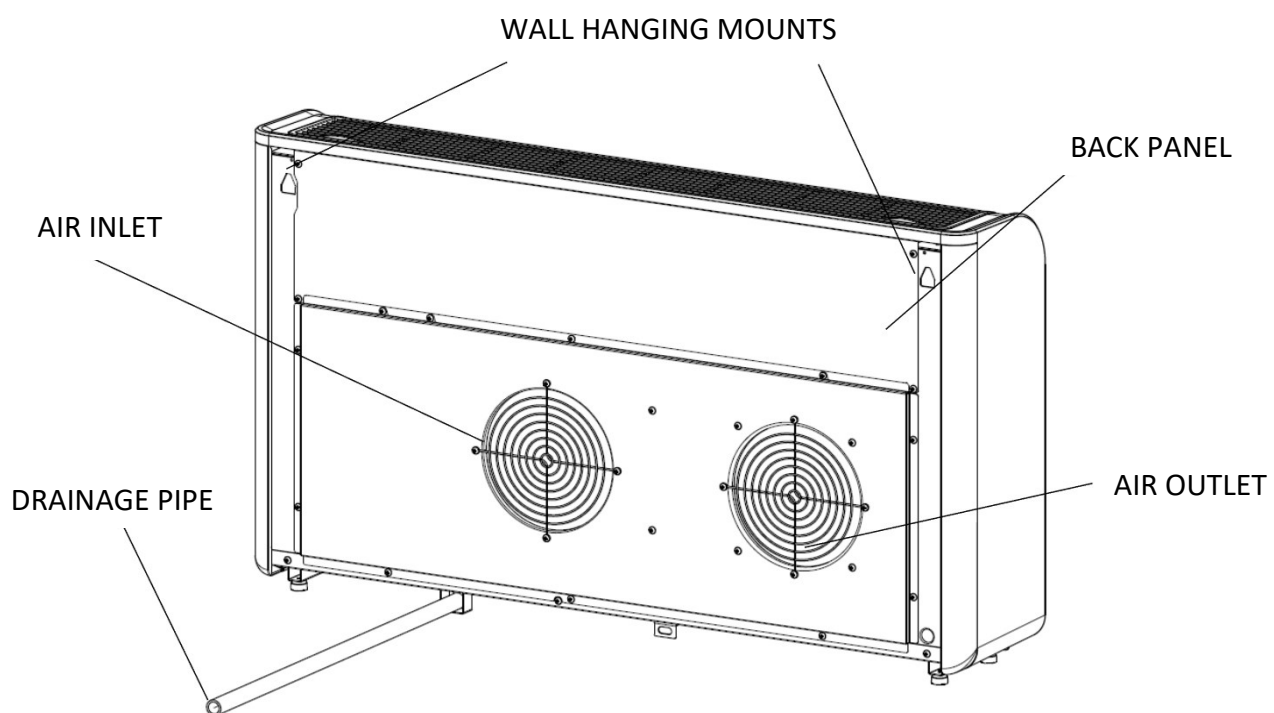



## FEATURES

- ◆ Simple operation.
- ◆ Self-evaporative function with energy saving technology.
- ◆ Sleek design that seamlessly fits into any style home.
- ◆ Bright LED screen-indicates temperature and current mode.
- ◆ On / off timer function-allows you to choose when the unit operates.
- ◆ WIFI App control providing additional functionality.
- ◆ Three fan speeds.
- ◆ Four modes to suit your every need including: Cooling / Heating / Fan / Dry
- ◆ Silent running option, perfect for a restful night sleep.

## WHATS INCLUDED

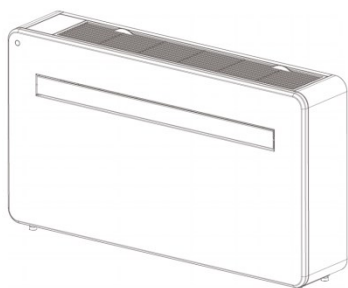

**AIR CONDITIONER**

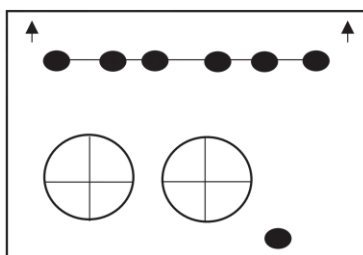

**WALL TEMPLATE**

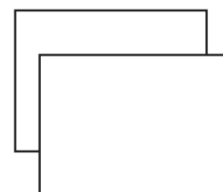

**PLASTIC DUCTING SHEET (X2)**

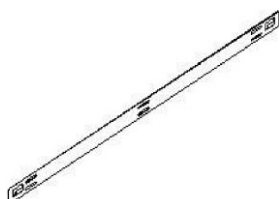

**WALL BRACKET**



**REMOTE CONTROL**



**VENT COVER ASSEMBLY (X2)  
(CHAIN, INDOOR RING AND OUTDOOR COVER)**



**FIXED PLATE**

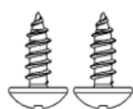

**2PCS TAPPING SCRE  
(4x10mm)**



**7PCS WALL PLUGS  
(8x40mm)**



**7PCS SCREWS (5x60mm)**



**Sealing strip**

**\* DIAGRAMS FOR ILLUSTRATIVE PURPOSES ONLY**

## INSTALLATION

Apply the sealing strip in the accessories along the edge of the back for the whole perimeter of the machine, cut off the excessive length if needed.

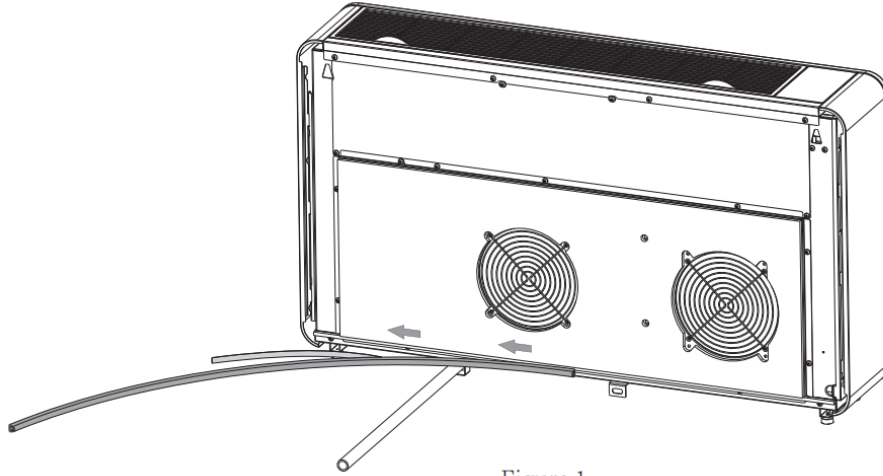

Figure 1

- Note :
- 1.The sealing strip should be applied along the edge of the machine, as shown in Figure1.
  2. Please peel the striping layer on the sealing strip gradually while applying.
  3. Apply from the bottom of the machine first.

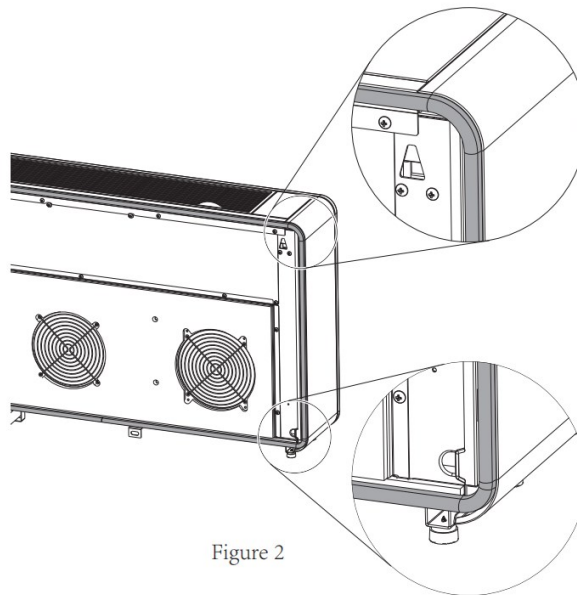
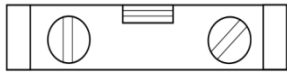

Figure 2

4. The position of the corner should be applied as shown in Figure 2.
5. Improper application may cause extra noise.

## TOOLS REQUIRED



SPIRIT LEVEL

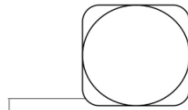

TAPE MEASURE

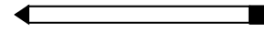

PENCIL

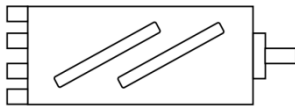

180mm CORE

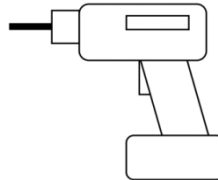

DRILL



SHARP KNIFE



8mm(5/16")MASONRY



25mm(1")MASONRY DRILL

**BEFORE STARTING INSTALLATION, PLEASE ENSURE YOU HAVE ALL SUITABLE EQUIPMENT AVAILABLE AND UNDERSTAND THE STEPS INVOLVED IN INSTALLATION. IF IN ANY DOUBT, PROFESSIONAL ADVICE SHOULD BE SOUGHT.**

**THE INSTALLER MUST ENSURE THAT THE PLANNED POSITION OF THE AIR CONDITIONER IS SUITABLE, AND THAT THERE ARE NO CABLES AND PIPES INSIDE THE WALL, AND NO OTHER OBSTRUCTIONS FIXED ON THE WALL, WHICH WOULD PRESENT A DANGER AND/OR PREVENT COMPLETION OF INSTALLATION.**

## INSTALLATION

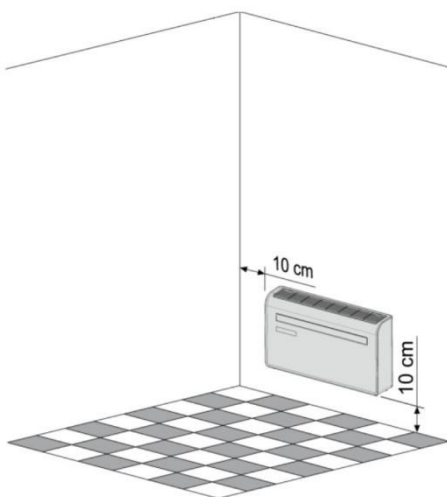

This unit must be installed on an external wall, as it vents directly out of its rear and ensure the wall is flat, solid and reliable.

Leave at least 10 cm (4 ") of space to the left, right and base of the machine. At least 20cm (8 ") of space must be left above the unit to help air flow smoothly and stay away from curtains, plants, faucets, furniture and others appliances etc.

Paste the supplied wall, ensuring that the

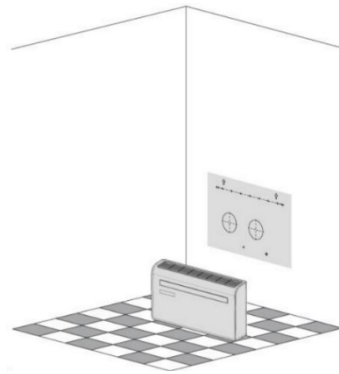

installation template paper in position on the reference line is level using a spirit level.

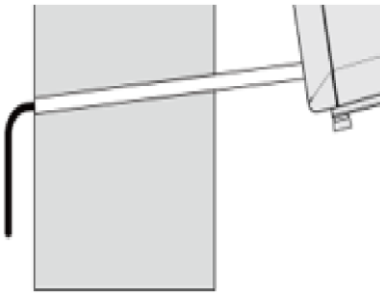

The hole for the drainage pipe must be drilled using a 25mm (1") Drill bit. Ensure the hole is at a downward angle (min 5 degrees) so that the water will drain correctly.

Use a 180mm core drill to drill the two holes for the units' Ventilation ducts, ensuring that the holes are at a downward angle toward the outdoors (min 5 degrees) and aligned with the template.

Use the template to mark the position of the screws for the hanging rail, using a spirit level to ensure it is straight and level. Drill the marked holes using a suitable 8mm(5/16") drill bit and insert wall plugs. Line up the hanging rail with the holes, and fix the rail into position using the supplied screws.

Ensure that the hanging rail is securely fastened onto the wall, and that there is no risk of the unit tipping or falling.

The machine performs best when it is installed on a wall with a thickness not exceeding 240mm.

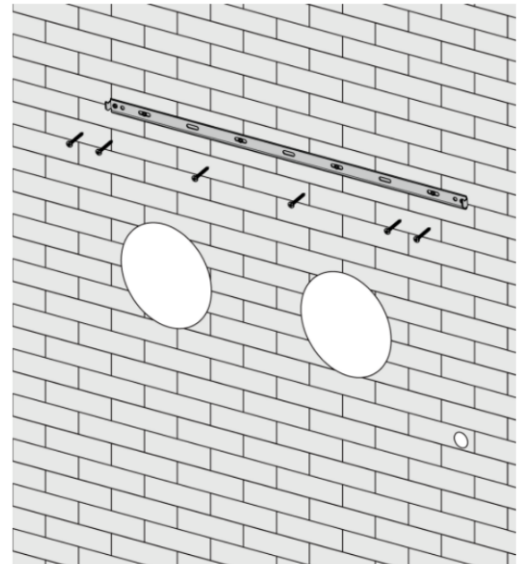

Roll the plastic vent sheets into a tube and feed them from the inside into the holes previously made. Ensure the tubes sit flush to the interior wall and the splicing line "A" always faces upwards.

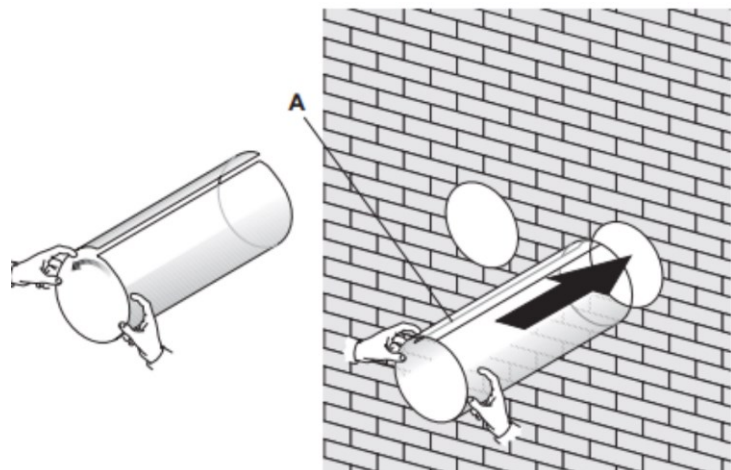

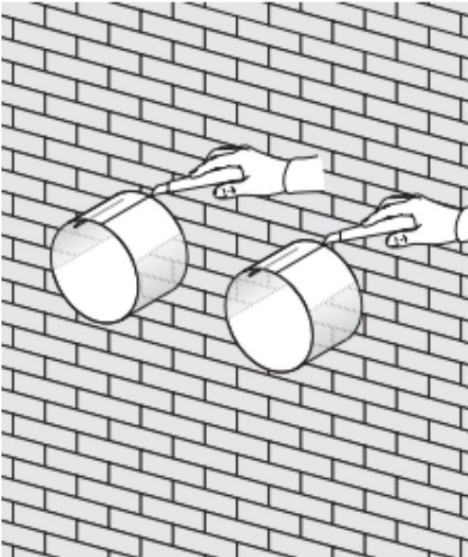

Trim off the excess vent tube using a sharp knife, keeping the edge as neat as possible.

Insert the indoor fixing ring from the vent cover onto the indoor side of the air vent. Then fold the external vent cover in half. Attach the chains to each side of the vent cover, before sliding the cover outside through the vent hole.

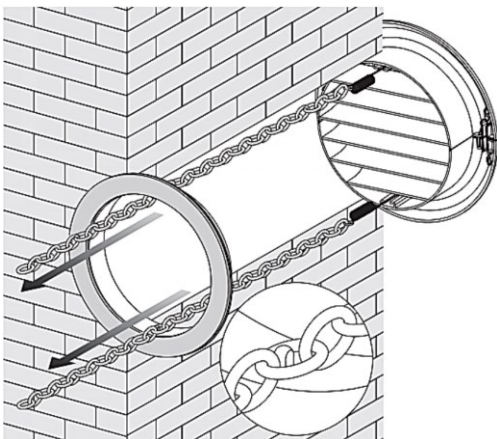
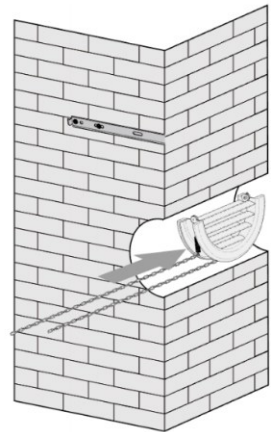
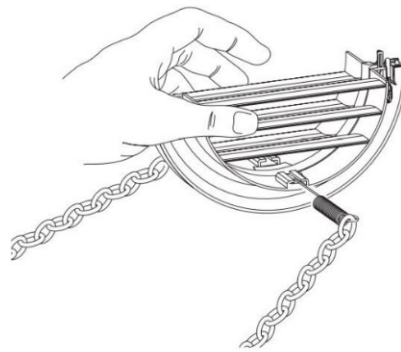

Expand the external cover, before tightly fixing the chains by hooking onto the indoor fixing ring. This will hold the external cover firmly in position. Repeat for the second vent.

Once the chains are fitted and secured, any excess chain should be removed by cutting the chain.

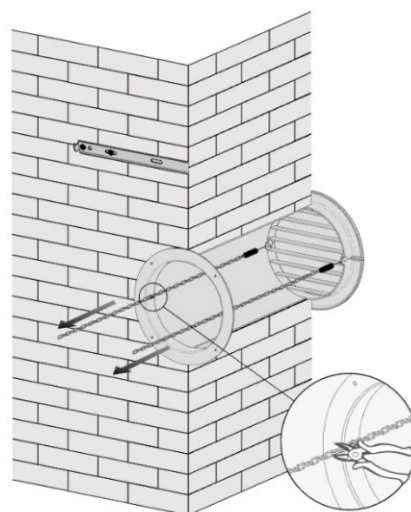
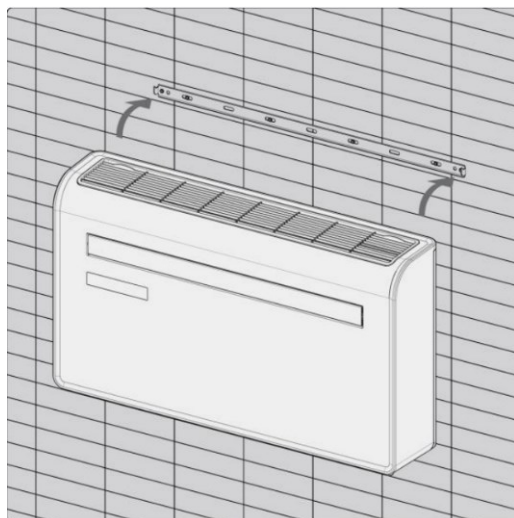

Lift the unit onto the wall, align the hanging holes with the hooks on the hanging rail and gently rest the unit into place. At the same time, slide the drain pipe through the drainage hole.

**NOTE:**

1<sup>st</sup>: please ensure that the backside of product is tightly attached on the wall to avoid additional vibration and noise.

2<sup>nd</sup> : The end of the external water pipe must be placed in an open space or drain. Avoid damage or constriction to the drainage pipe to ensure the unit drains.

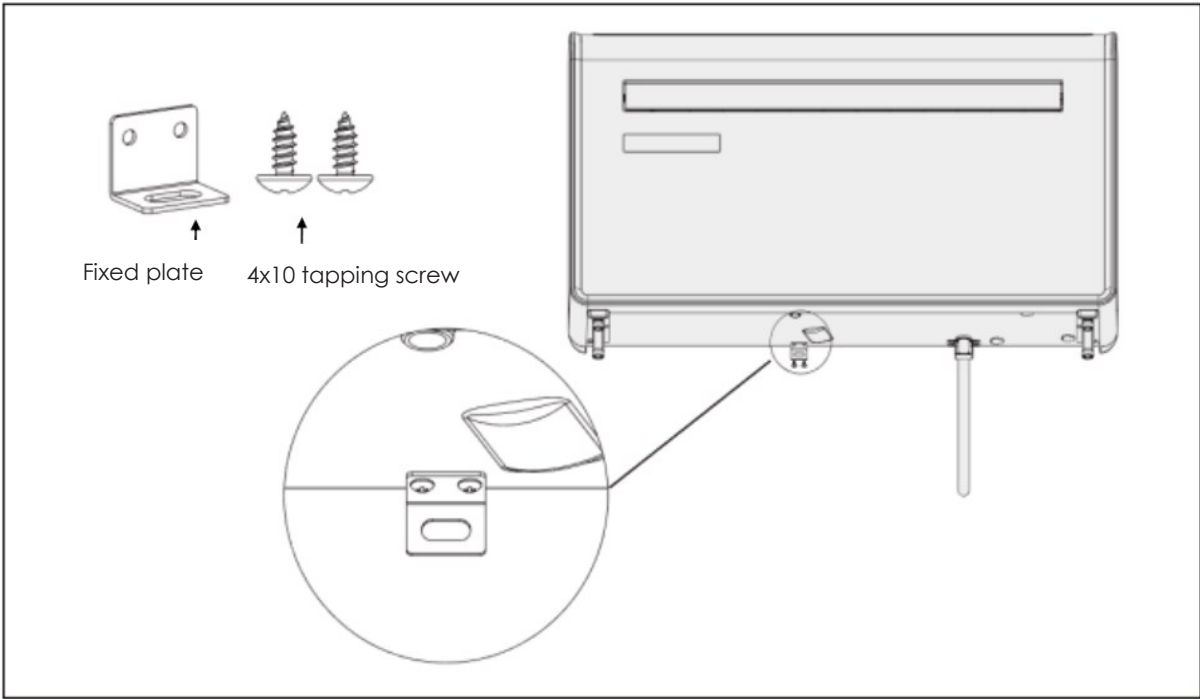

# OPERATION

## CONTROL PANEL

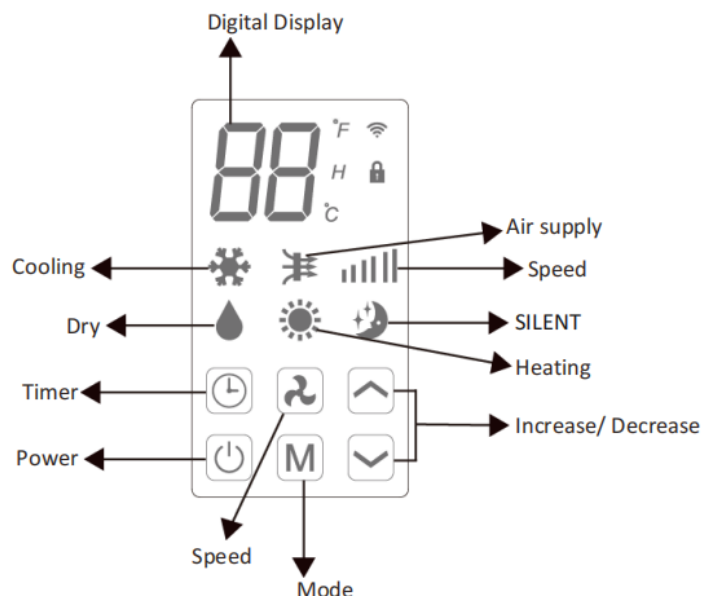

## REMOTE CONTROL

The air conditioner can be controlled with the remote control. Two AAA-batteries are required.  
 NOTE: Further details of the functions can be found on the following page.

<b>POWER</b>	Press the POWER button to turn the machine on or off.	
<b>MODE</b>	Press the MODE button to switch between cooling, heating, fan and dry modes.	
<b>FAN</b>	Press the FAN button to change between high, medium and low fan speeds	
<b>LED</b>	Press the LED button to open or close the LED background light of unit, it can be a choice for sleep condition.	
<b>▲</b>	Press the UP button to increase the desired temperature or timer duration	
<b>▼</b>	Press the DOWN button to decrease the desired temperature or timer duration	
<b>SILENT</b>	Press it for silent mode, In Silent mode, noise will be lower, fan works in low speed, frequency is low.	
<b>SWING</b>	Press to turn the louver swing function on and off (only activated by the remote control & APP)	
<b>TIMER</b>	Press the TIMER button to set the automatic switch on/off.	
<b>TEMP</b>	It can be changed between °F and °C, by pressing "UP" and "DOWN" button on the display at the same time	



## INSERTING AND REPLACING BATTERIES

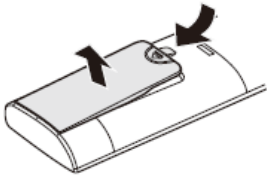

Your air conditioning unit comes with two AAA batteries. Put the batteries in the remote control before use.

1. Remove the cover on the back of the remote control.
2. Insert the new batteries and make sure that the (+) and (-) terminals of the batteries are installed correctly.

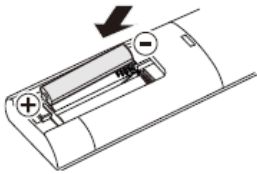

### BATTERY NOTES

For optimum product performance:

1. Do not mix old and new batteries, or batteries of different types.
2. Do not leave batteries in the remote control if you don't plan on using the device for more than 2 months.

### BATTERY DISPOSAL

Do not dispose of batteries as unsorted municipal waste. Refer to local laws for proper disposal of batteries.

### TIPS FOR USING REMOTE CONTROL

The remote control must be used within 8 meters / 26 feet of the unit.

The unit will beep when remote signal is received.

Curtains, other materials and direct sunlight can interfere with the infrared signal receiver.











Remove batteries if the remote will not be used more than 2 months.

### NOTES

- When there are wide differences between remote controller illustration and "USER'S MANUAL" on function description, the description on "USER'S MANUAL" shall prevail.
- The device could comply with the local national regulations. In Canada, it should comply with CAN ICES-3(B)/NMB-3(B). In USA, this device complies with part 15 of the FCC Rules. Operation is subject to the following two conditions: (1) This device may not cause harmful interference, and (2) this device must accept any interference received, including interference that may cause undesired operation.
- This equipment has been tested and found to comply with the limits for a Class B digital device, pursuant to part 15 of the FCC Rules. These limits are designed to provide reasonable protection against harmful interference in a residential installation. This equipment generates, uses and can radiate radio frequency energy and, if not installed and used in accordance with the instructions, may cause harmful interference to radio communications. However, there is no guarantee that interference will not occur in a particular installation. If this equipment does cause harmful interference to radio or television reception, which can be determined by turning the equipment off and on, the user is encouraged to try to correct the interference by one or more of the following measures:

- Reorient or relocate the receiving antenna.
- Increase the separation between the equipment and receiver.
- Connect the equipment into an outlet on a circuit different from that to which the receiver is connected.
- Consult the dealer or an experienced radio/TV technician for help. Changes or modifications not approved by the party responsible for compliance could void user's authority to operate the equipment.

## FUNCTIONS

 <b>POWER</b>	Press "POWER" to turn the unit On or Off.	
 <b>MODE</b>	Press to change between the 4 different modes. The display will show the symbol for the mode currently selected.	
	 <b>COOLING</b>	The cooling function allows the air conditioner to cool the room and at the same time reduces air humidity. The desired temperature can be adjusted using the increase and decrease button between 60°F/15°C and 86°F/30°C. The fan speed can also be adjusted using the speed button.
	 <b>DRY</b>	Dry mode will extract moisture from the air, which will be drained outside using the installed drain pipe. the fan speed cannot be adjusted in dry mode.
	 <b>FAN</b>	In fan mode the appliance will recirculate the air within the room, and will not cool, heat or dehumidify. The fan speed can be adjusted using the Speed button, But the desired temperature can not be set.
	 <b>HEATING</b>	The heating function allows the air conditioner to heat the room. The desired temperature can be adjusted using the increase and decrease button between 60°F and 86°F. The fan speed can also be adjusted using the speed button.
	 <b>SILENT</b>	Silent mode can be activated from APP or the remote control, It will only operate in cooling or heating modes, the fan speed will change to low and noise will be lower.
 <b>FAN SPEED</b>		Press to change the fan speed between Low, Medium and High. The fan speed cannot be adjusted in Dry or Silent modes.
 <b>TIMER</b>	The air conditioner contains a 24 hour timer, which can be used to either set a delayed start, or a set period of operation.	
	<b>SHUTDOWN TIMER:</b> While the unit is running press the timer button, the display will flash "0" 5 times. After the 5th flash, use the up and down buttons to adjust the duration in 1 hour increments between 1 to 24 hours. When the timer has elapsed, the unit will shutdown automatically.	
	<b>DELAYED START TIMER:</b> With the unit in standby, press the timer button, the display will flash "0" 5 times. After the 5th flash, use the up and down buttons to adjust the duration in 1 hour increments between 1 to 24 hours. After the timer has elapsed, the unit will start up in the same mode with the same settings as when it was turned off.	

 INCREASE AND DECREASE	Used within cooling and heating modes to adjust the desired temperature 60-86°F/15°C-30°C. Also used while setting the timer to adjust the duration.
SWING MODE	After machine turns on, press the "SWING" button, louver will swing continuously up and down; by pressing the button again the movement will stop and the louver remain in that position. Swing mode can only be adjusted from the remote, and will initially be turned on by default. The louver will close automatically once you switch OFF the product.
COMPRESSOR PROTECTION	There is a 3 minutes delay on power on. In order to protect the life of the compressor and electronic components please do not switch on the unit for at least 5 minutes after you turned the unit off.

## WIFI SETUP AND SMART FEATURES

### WIFI SETUP

#### BEFORE YOU START

- Ensure your router provides a standard 2.4ghz connection.
- If your router is dual band ensure that both networks have different network names (SSID). The provider of your router / Internet service provider will be able to provide advice specific to your router.
- Place the air conditioner as close as possible to the router during setup.
- Once the app has been installed on your phone, turn off the data connection, and ensure your phone is connected to your router via WIFI.

#### DOWNLOAD THE APP TO YOUR PHONE

Download the "SMART LIFE" app, from your chosen app store, using the QR codes below, or by searching for the app in your chosen store.



## REGISTER THE APP

If you don't have an App account , register an account or sign in with verification code by SMS. This page describes the registration process.

1. Press on the “Sign Up” button at the bottom of the screen, as shown in the picture 1.
2. The system automatically recognizes your country/ area. You can also select your country code manually. Enter your mobile phone number/ email address and tap "Get verification code", as shown in the picture 2.
3. If you choose the mobile number option, then enter the verification code in the message sent to you by SMS. Set a password as prompted and press "Done" to finish your registration. as shown in the picture.

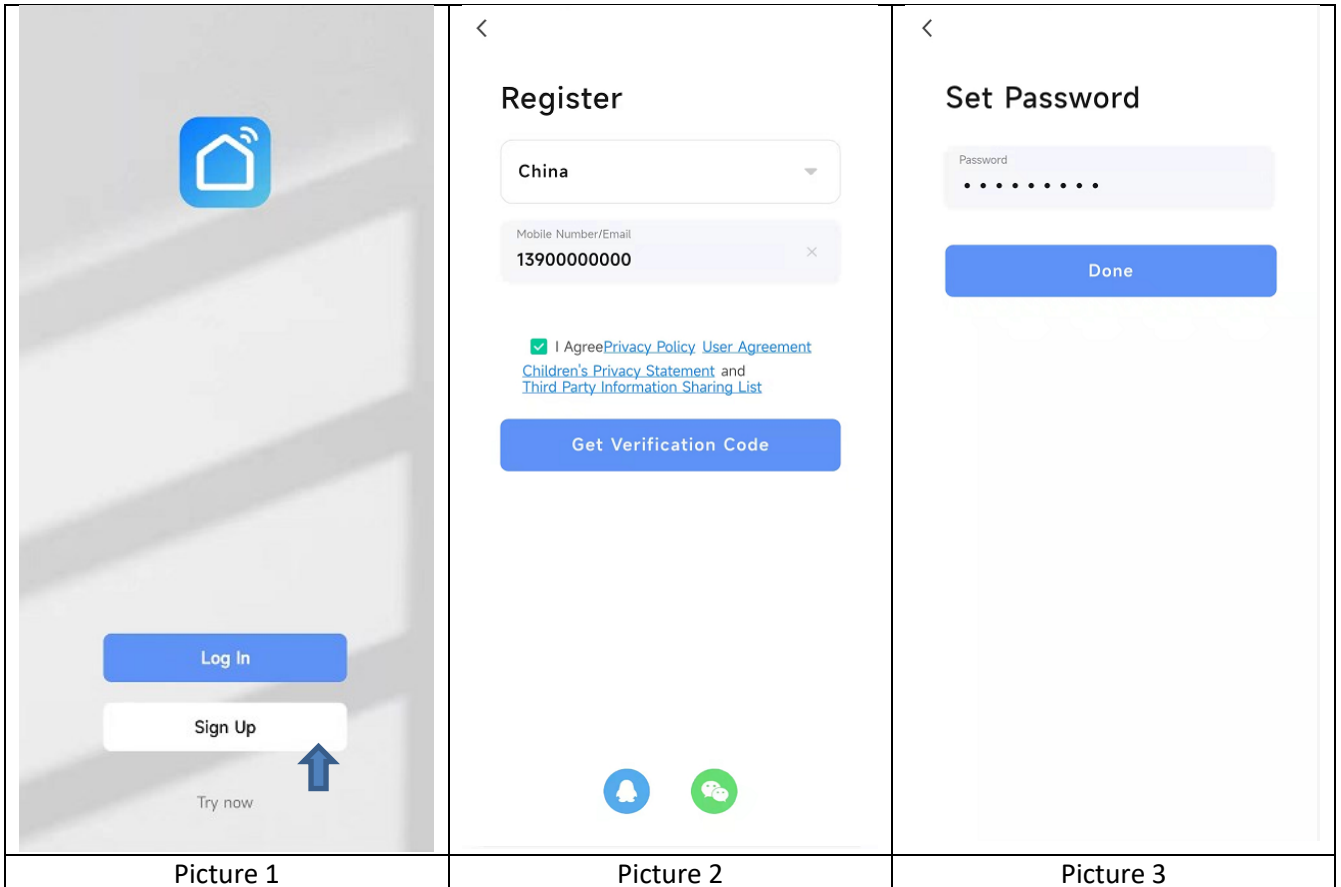

## WiFi CONNECTION MODE

In Standby mode press and hold the fan speed button for 3 seconds (until you hear a bleep) to enter the WiFi connection mode.

Please ensure your device is in the correct WiFi connection mode for the connection type you are attempting, the flashing of the WiFi light on your air conditioner will indicate this.

Connection Type	Frequency of Flashes
Quick Connection	Flashes twice per second
AP Connection (Access Point)	Flashes once per three seconds

## CHANGING BETWEEN CONNECTION TYPES

To change the unit between the two WiFi connection modes, hold the Speed button for 3 seconds.

### CONNECTING USING BLUETOOTH & WIFI

Before initiating the connection, make sure the unit is in standby mode and connected to the wifi network.

1. Open the Bluetooth of your phone, as shown in the picture 4.
2. When the device is powered on and to be connected, the connected Bluetooth device will pop up automatically after opening the App for a moment. Click "Add" button for connection, as shown in the picture 5.
3. Enter the Wi-Fi information interface, enter the password and click "Next" to continue the operation, as shown in the picture 6.

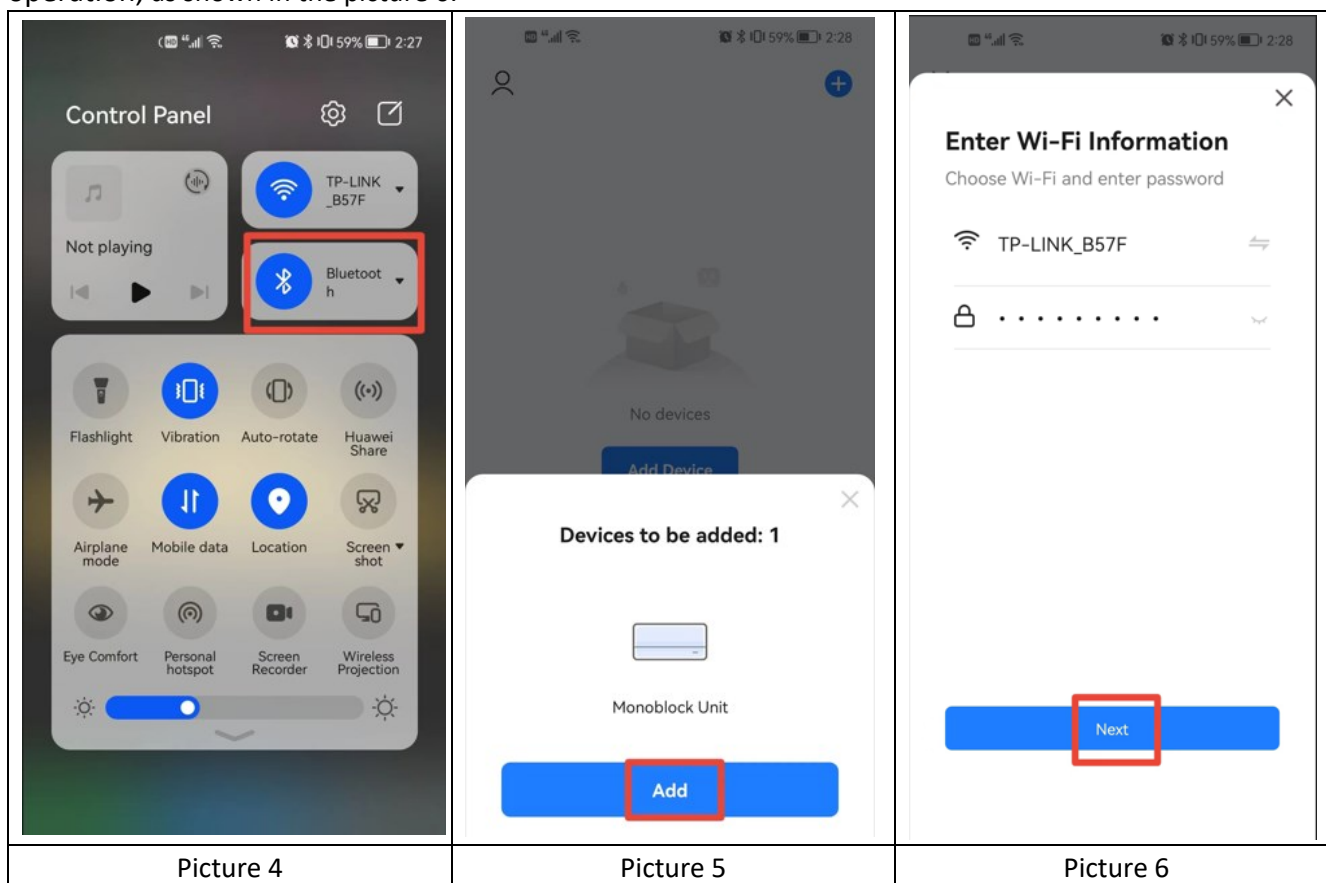

4. Enter the device connection interface after the progress bar is finished and the device is successfully connected, as shown in the picture 7,8,9.

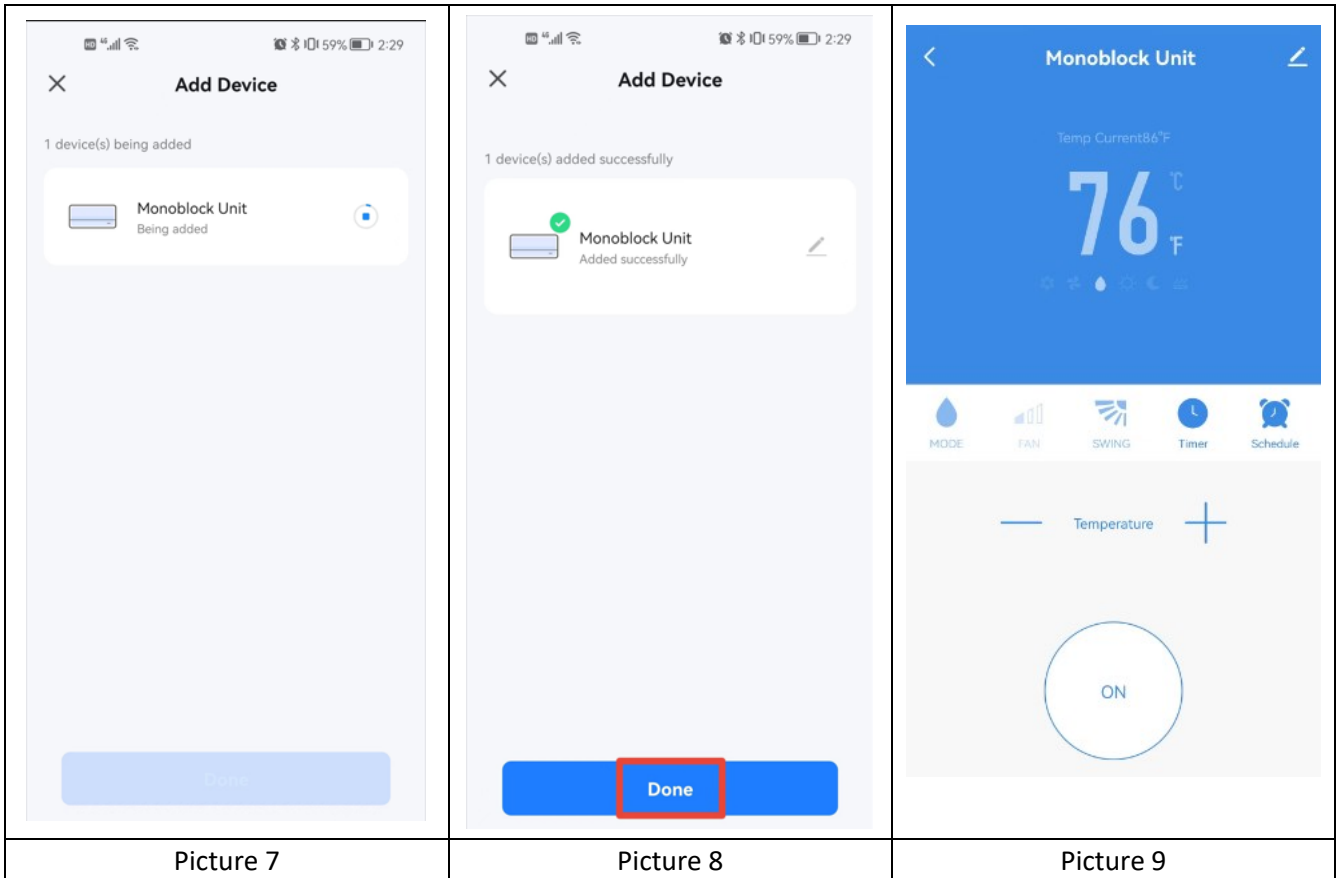

If you don't want to use Bluetooth connection, just need to Exit the Bluetooth connection prompt or turn off Bluetooth and follow the below steps to connect the unit with Wifi connection.

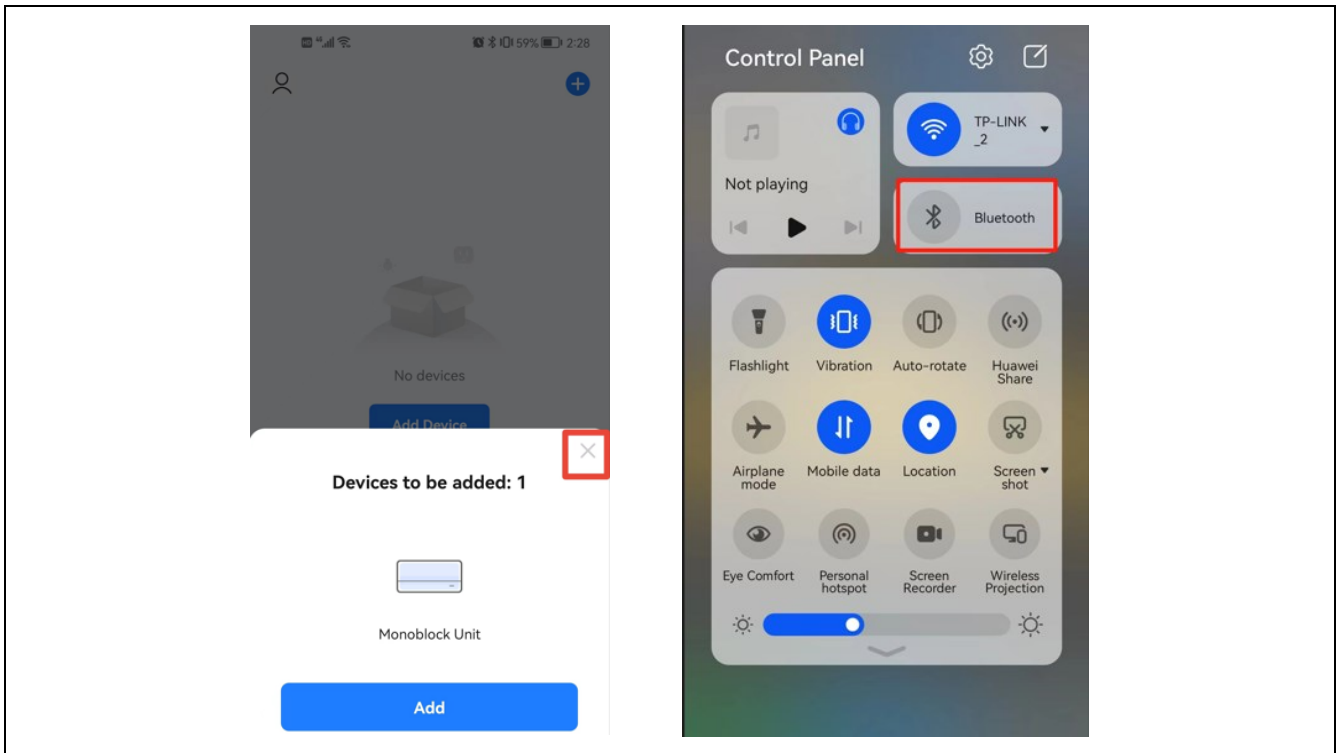

1. Click "Add Device" for operation, as shown in the picture 10.
2. Select the type of device as "Large Home Appliance", as shown in the picture 11.

3. Connect a WIFI and enter the password., as shown in the picture 12.

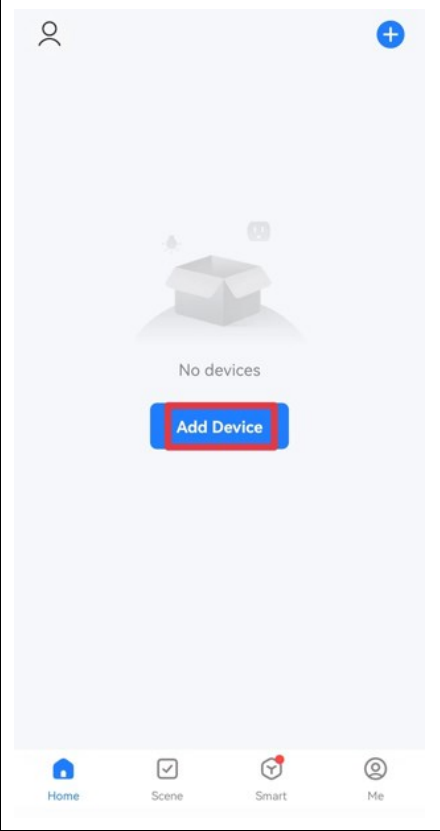
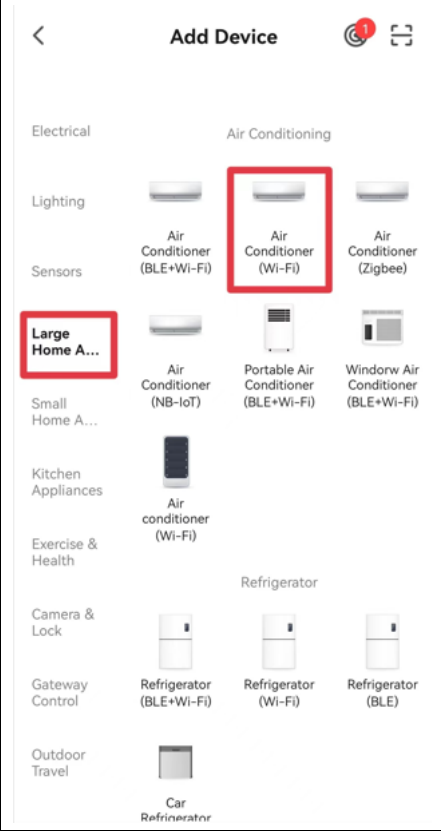
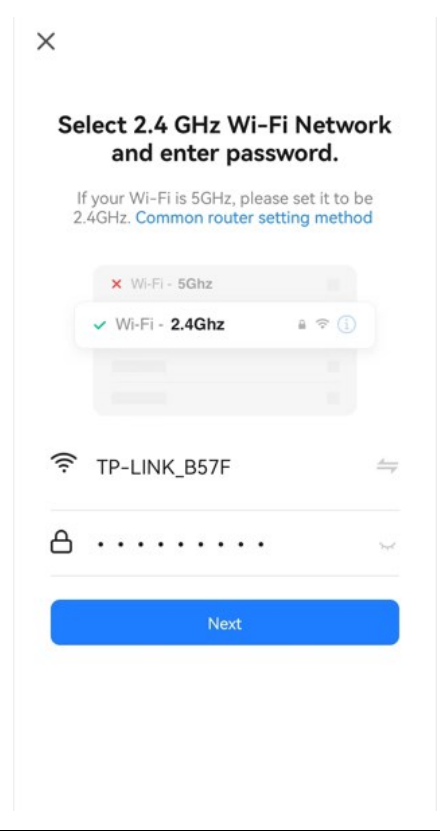
 <p>The screenshot shows the 'Add Device' screen with a grid of categories. A red box highlights the 'Add Device' button at the bottom. The categories include Electrical, Lighting, Sensors, Large Home A..., Small Home A..., Kitchen Appliances, Exercise &amp; Health, Camera &amp; Lock, Gateway Control, Outdoor Travel, Air Conditioning, and Refrigerator.</p>	 <p>The screenshot shows the 'Add Device' screen with a grid of categories. A red box highlights the 'Air Conditioner (Wi-Fi)' option under the 'Air Conditioning' category. The categories include Electrical, Lighting, Sensors, Large Home A..., Small Home A..., Kitchen Appliances, Exercise &amp; Health, Camera &amp; Lock, Gateway Control, Outdoor Travel, Air Conditioning, and Refrigerator.</p>	 <p>The screenshot shows the 'Select 2.4 GHz Wi-Fi Network and enter password.' screen. It displays a list of networks, with 'Wi-Fi - 2.4Ghz' selected. A red box highlights the 'Next' button at the bottom. The screen also shows a warning for 'Wi-Fi - 5Ghz' and a password field.</p>
<p>Picture 10</p>	<p>Picture 11</p>	<p>Picture 12</p>

4. Ensure the WIFI light on the air conditioner is flashing twice per second, as shown in the picture 13.

5. Enter the device connection interface after the progress bar is finished and the device is successfully connected. Click the "Done" button to enter the operation interface of the device, as shown in the picture 14,15

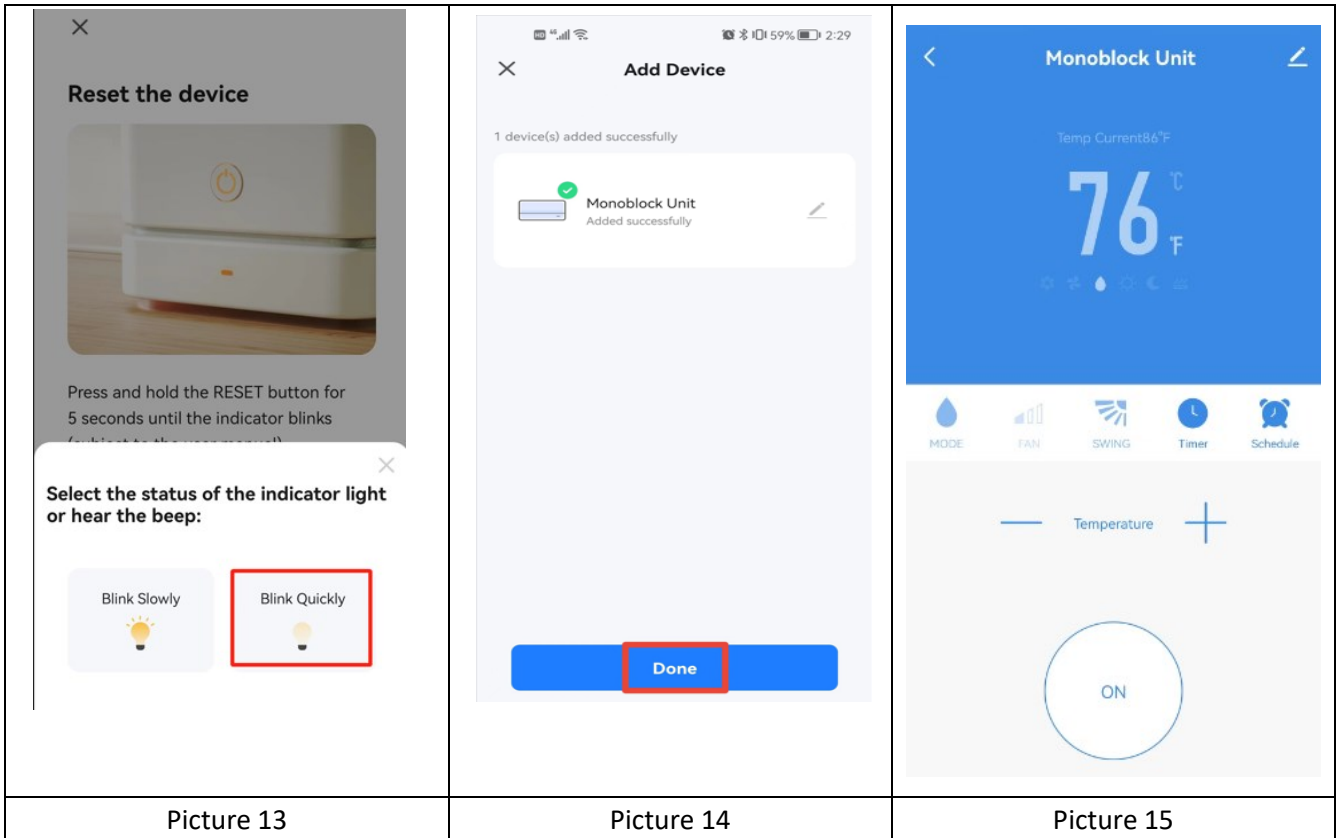

Picture 13

Picture 14

Picture 15

**\*Due to continuous development of the app, the layout and available features may be subject to change.**

## TROUBLESHOOTING

Do not repair or disassemble the air conditioning. Unqualified repair will invalidate the warranty and may lead to failure, causing injuries and property damage. Only use it as directed in this user manual and only perform operations advised here.

Problem	Reasons	Solutions
The air conditioner does not work	There is no electricity.	Check the unit is plugged in, and the socket is working normally.
	The ambient temperature is too low or too high.	Only use to use the machine with a room temperature between 23°F/-5°C and 95°F /35°C.
	In cooling mode, the room temperature is lower than the desired temperature; in heating mode, the room temperature is higher than the desired temperature.	Adjust the desired room temperature.
	In dehumidification (dry) mode, the ambient temperature is low.	Ensure that the room temperature is above 62°F/17°C for dry mode.
	There is direct sunlight.	Use curtains to reduce heat from the sun.



The cooling or heating effect is poor	Doors or windows are open; there are a lot of people; or in cooling mode, there are other sources of heat (e.g. fridges)	Close doors and windows; increase air conditioning power
	The filters screen is dirty.	Clean or replace the filter screen.
	The air inlet or outlet is blocked.	Clear obstructions; make sure the unit is installed as per the instructions
The air conditioner is leaking	The unit is not straight	Use a spirit level to check the unit is horizontal, if not remove from the wall and Straighten.
	The drain pipe is blocked	Check the drain pipe to ensure it is not blocked or constricted.
Compressor does not work.	Overheat protection operational .	Wait for 3 minutes until the temperature is lowered, and then restart the machine.
The remote control does not work.	The remote control is not aligned with the direction of the remote-control receiver.	Let the remote control get close to the air conditioner, and make sure that the remote control directly faces to the direction of the remote-control receiver.
	Batteries poor.	Replace batteries.

**If problems not listed in the table occur or recommended solutions do not work, please contact the service centre.**

## ERROR CODES

Fault Code	Fault Description	Fault Code	Fault Description
F1	Compressor IPM error	P7	Defrost protection on coil tube(indoor)
F2	PFC/IPM error	P8	Zero-crossing fault detection(indoor)
F3	Compressor start error	PA	Return air sensor temperature abnormal protection
F4	Compressor running out of step	PC	Coil tube overload protection(outdoor)
F5	Location detection loop failure	PE	Abnormal refrigerant circulation
F6	PCB and driver board communication error	PH	Exhaust temperature protection
F7	Coil sensor error(outdoor)	E0	Sensor on suction pipe error
F8	Sensor on suction pipe error	E1	Temperature sensor error(indoor)
FA	Phase current overcurrent protection	E2	Sensor error on indoor coil tube
FE	EE error(outdoor)	E3	DC fan Feedback failure(indoor)
FL	Water-full protection	E4	Indoor and outdoor communication error
P1	Over-heat protection on top of compressor	E5	Water-splash motor error
P2	Dc bus voltage Undervoltage protection	E6	Temperature sensor error(outdoor)

P3	AC Input voltage protection	E7	Fan motor error(outdoor)
P4	AC over-current protection	E8	Fan feedback fault
P5	AC undervoltage protection	EE	EE error(indoor)
P6	Coil tube overload protection(indoor)		

## Maintenance

**Note: Please turn off the unit and unplug it before cleaning.**

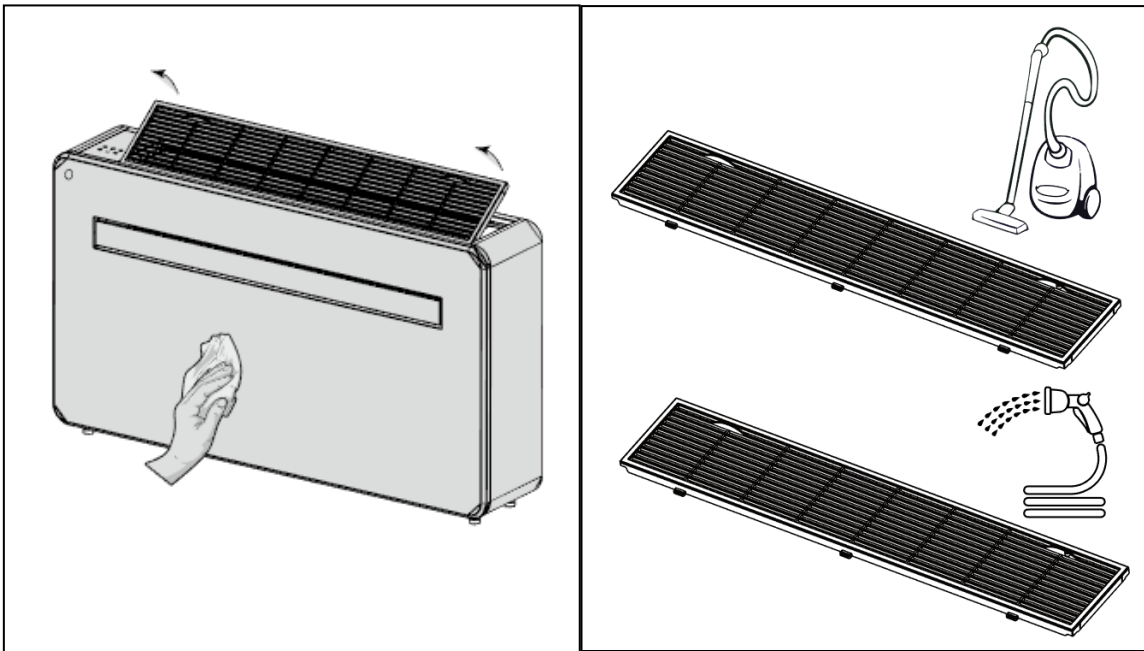

1. The filter can be removed in the direction shown in picture. After removal, the filter can be vacuumed and cleaned. The surface of the filter can be installed in the original place after drying.
2. Do not open the case to clean the inside of the fuselage, if you really need to clean, please contact professionals;
3. If cleaning the surface of the unit, please use a semi-wet soft cloth or neutral detergent to wipe, do not use such as benzene, gasoline, alcohol and other chemical solvents to wipe the air conditioner.

## Sociable Remark

When using this product, the following information must be followed:

### DISPOSAL

Do not dispose this product as unsorted municipal waste. Collection of such waste separately for special treatment is necessary.

It is prohibited to dispose of this appliance in domestic household waste. For disposal, there are several possibilities:

- A. The municipality has established collection systems, where electronic waste can be disposed of at least free of charge to the user.

- B. When buying a new product, the retailer will take back the old product at least free of charge.
  - C. The manufacture will take back the old appliance for disposal at least free of charge to the user.
  - D. As old products contain valuable resources, they can be sold to scrap metal dealers.
- Wild disposal of waste in forests and landscapes endangers your health when hazardous substances leak into the ground-water and find their way into the food chain.

